

USER MANUAL

Data Loggers Class 120

TABLE OF CONTENTS

1 SAFETY INSTRUCTIONS.....	4
1.1 Precautions.....	4
1.2 Symbols.....	4
2 DEVICE COMPONENTS.....	5
2.1 Use.....	5
2.2 Applications.....	5
2.3 Layout.....	6
2.4 PC connection.....	6
2.5 Mounting.....	6
3 TECHNICAL FEATURES.....	7
3.1 Devices.....	7
3.2 Housing.....	7
3.3 Dimensions.....	8
3.4 Directive: FCC part 15.....	8
3.5 Warranty period.....	8
4 USE OF THE DEVICE.....	9
4.1 Display.....	9
4.2 Configuration, data logger download and data processing with the KILOG software.....	9
4.3 Functions of buttons.....	10
4.3.1 Groups organization.....	11
4.4 Data logger configuration with the on-board integrated PDF file.....	12
4.5 Data logger download with PDF report edition.....	15
5 DEVICE MAINTENANCE.....	17
5.1 Replace the battery.....	17
5.2 Device cleaning.....	17
6 CALIBRATION.....	19
7 ACCESSORIES.....	19
8 TROUBLESHOOTING.....	19

1 SAFETY INSTRUCTIONS

1.1 Precautions

Please always use the device in accordance with its intended use, and within the parameters described in the technical features page 7 in order not to compromise the protection ensured by the device.

Changes or modifications not expressly approved by Sauermann could void the user's authority to operate the equipment.

1.2 Symbols

For your safety and in order to avoid any damage to the device, please follow the procedures described in this user manual and carefully read the notes preceded by the following symbol:



The following symbol will also be used in this user manual:
Please carefully read the information notes indicated after this symbol.



2 DEVICE COMPONENTS

2.1 Use

The devices have a male USB plug and on-board integrated software in PDF format to download and configure the data logger without additional software.

2.2 Applications

The data logger is ideal for temperature and humidity monitoring of the sensitive product storage, for example in the food industry or pharmaceutical domain. It allows the monitoring of temperature and humidity in refrigerators, cold rooms and food trucks.

Therefore, the device guarantees a traceability all along the cold chain. And at any moment, easily and quickly edit and produce a PDF data report.



2.3 Layout



"OK" button: confirm, start and stop the dataset, display the value



"Selection" button: scroll between functions

2.4 PC connection



2.5 Mounting

The KT120 and KH120 data loggers are equipped with a magnetic case for easy mounting.

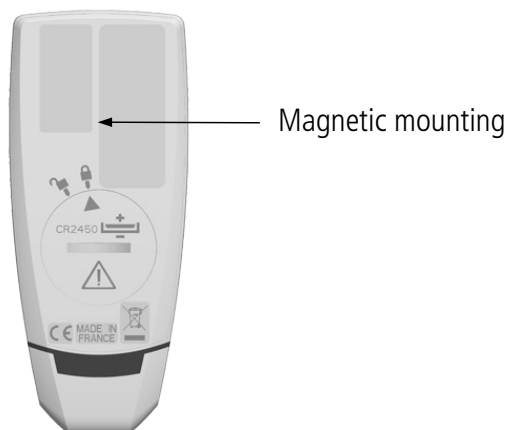

3 TECHNICAL FEATURES

3.1 Devices

	KT 120	KH 120
Units displayed	°F, °C	°F, °C, %RH
Resolution	0.1°F, 0.1°C	0.1°F, 0.1°C, 0.1%RH
External input	USB connector	USB connector
Internal sensor	Temperature	Temperature, humidity
Type of sensor	Thermistor (NTC)	Thermistor (NTC), Capacitive
Measuring range	-40 to 158°F (-40 to 70°C)	Temp.: -4 to 158°F (-20 to 70°C) Humidity: 0 to 100%RH
Accuracies¹	±0.8°F from -4 to 158°F (±0.4°C from -20 to 70°C) ±1.5°F below -4°F (±0.8°C below -20°C)	Temp: ±0.8°F from 32 to 122°F (±0.4°C from 0 to 50°C) ±1.5°F below 32°F or above 122°F (±0.8°C below 0°C or above 50°C) Humidity ² : ±2%RH (from 5 to 95%RH @ 59°F to 77°F) (15°C to 25°C)
Alarm set points	2 alarm set points per channel	2 alarm set points per channel
Number of points	50,000	50,000
Frequency of measurement	1 min to 24 h	1 min to 24 h
Operating temperature	-40 to 158°F (-40 to 70°C)	-4 to 158°F (-20 to 70°C)
Storage temperature	-40 to 185°F (-40 to 85°C)	-40 to 185°F (-40 to 85°C)
Battery life	3 years ³	500 days ³
Warranty	1 year	1 year
Directives	2011/65/EU RoHS II; 2012/19/EU WEEE; FCC part 15; UL 61010	

¹ All accuracies specified in this document were conducted in laboratory conditions and can be guaranteed for measurement carried out in the same conditions, or carried out with calibration compensation.

² Factory calibration uncertainty: ±0.88%RH; Temperature dependence: ±0.04 x [(T °F - 32) x 5/9 - 20] %RH (if T < 59°F or T > 77°F) / ±0.04 x (T - 20) %RH (if T < 15°C or T > 25°C)

³ On the basis of 1 measurement each 15 minutes at 77°F (25°C)

3.2 Housing

Dimensions	3.94" x 1.67" x 0.63" (100 x 42.5 x 15.9 mm)
Weight	1.9 oz (53 g)
Display	1-line LCD screen Screen: 1.27" x 1.28" (32 x 25.5 mm)
Control	1 OK button 1 Selection button
Material	Compatible with food industry environment ABS housing
Protection	IP65: KT 120 IP40: KH 120
PC communication	1 USB A male input
Battery power supply	1 x CR2450 (button battery)
Environmental conditions of use	Non-corrosive or combustible gases Humidity: in non condensing conditions Maximum altitude: 6561' (2000 m)

3.3 Dimensions

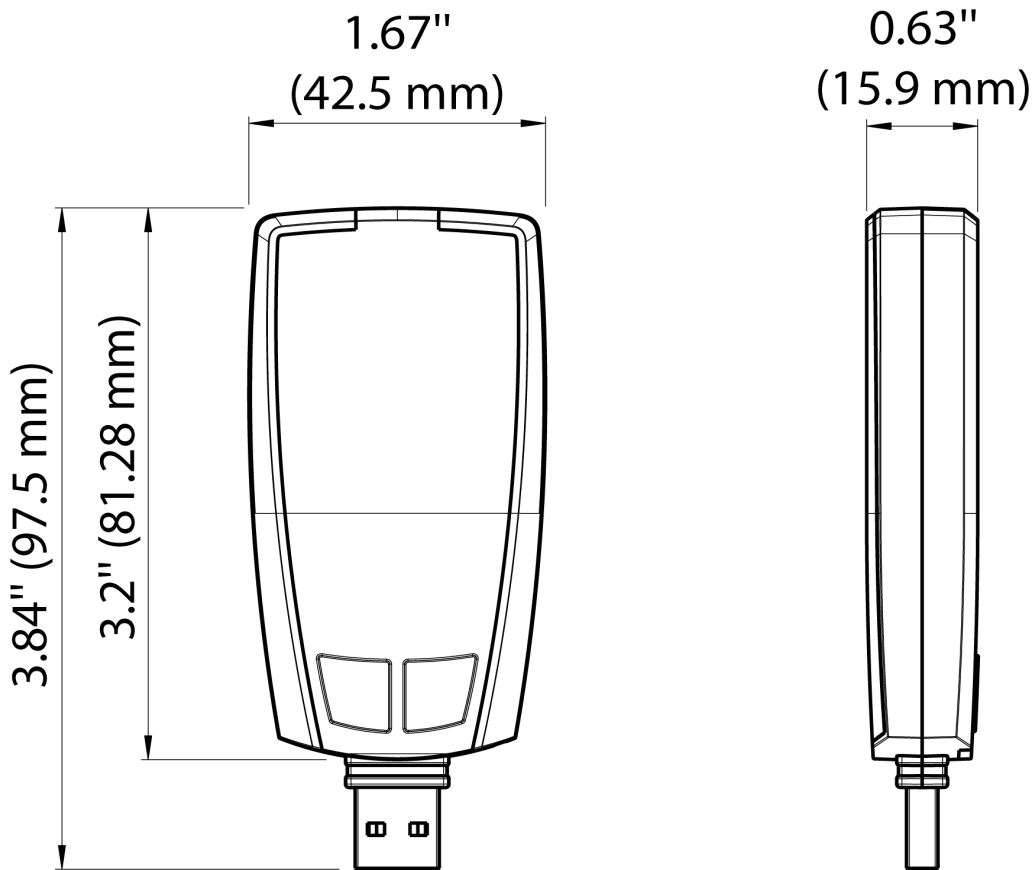

3.4 Directive: FCC part 15

 **Changes or modifications not expressly approved by Sauer mann could void the user's authority to operate the equipment.**

This equipment has been tested and found to comply with the limits for a Class B digital device, pursuant to part 15 of the FCC Rules. These limits are designed to provide reasonable protection against harmful interference in a residential installation. This equipment generates uses and can radiate radio frequency energy and, if not installed and used in accordance with the instruction, may cause harmful interference to radio communications. However, there is no guarantee that interference will not occur in a particular installation. If this equipment does cause harmful interference to radio or television reception which can be determined by turning the equipment off and on, the user is encouraged to try to correct interference by one or more of the following measures:

- Reorient or relocate the receiving antenna.
- Increase the separation between the equipment and receiver.
- Connect the equipment into an outlet on circuit different from that to which the receiver is connected.
- Consult the dealer or an experienced radio/TV technician for help.

3.5 Warranty period

Sauer mann data loggers have a 1-year warranty for any manufacturing defect (warranty returns must be processed through Sauer mann's After-Sale Service Dept.).

4.1 Display

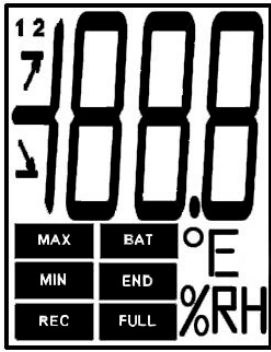

END DATASET is finished

REC Indicates that one value is being recorded. Flashing: the DATASET did not start.

FULL Flashing slowly: DATASET is between 80% and 90% of the storage capacity.
Flashing quickly: DATASET is between 90% and 100% of the storage capacity.
Constant: storage capacity full.

BAT Constant: indicates that the batteries have to be replaced.

12 Indicates the channel number being measured.

MIN The displayed values are the recorded maximum/minimum values for the displayed channels.

MAX





Indicates the alarm action type: rising or falling.

°F Temperature in °F.

°C Temperature in °C.

%RH Relative humidity (KH 120).

-  The selected values to display during the configuration with the KILOG software will scroll on the screen every 3 seconds (KH 120 only).
-  The display can be activated or deactivated via the KILOG software.
-  At extreme temperatures, the display can become difficult to read and the display speed can slow down at temperatures below 32°F (0°C). This has no effect on the measurement accuracy.















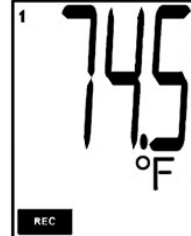







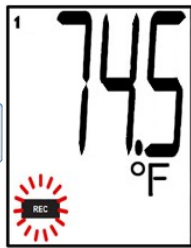

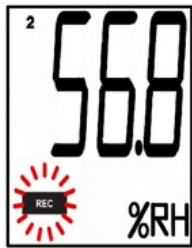

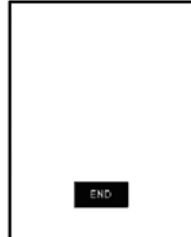

4.2 Configuration, data logger download and data processing with the KILOG software

Please see the KILOG software user manual: "KILOG-classes-50-120-220-320".

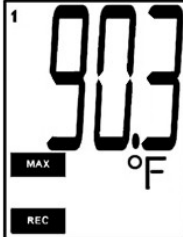

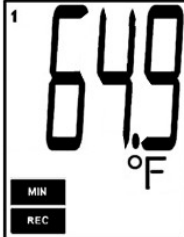

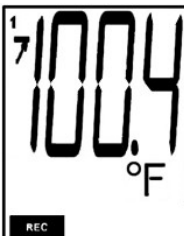

4.3 Functions of buttons

 **OK button:** start and stop the dataset (hold for > 3 seconds) or switch between scrolling groups as described in the following tables.

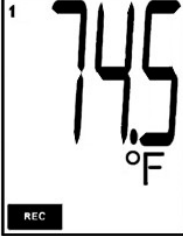
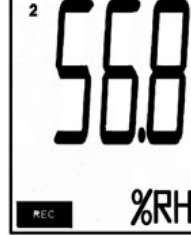
 **Selection button:** select values in the scrolling group as described in the following tables.

Device state	Type of start/stop selected	Button used	Action generated	Illustration
Waiting for start  flashes	Start: by button	 Hold for 3 seconds	Dataset starting	  Hold for 3 seconds 
	Stop: not relevant in this mode		Inactive	
	Start by PC or date/hour		Inactive	
	Stop: not relevant in this mode			
			Measurements scrolling (group 1)*	    Or wait 3 seconds  
Dataset in progress 	Start: not relevant in this mode	 During 3 seconds	Dataset stop	  Hold for 3 seconds 
	Stop: by button			
	Start: not relevant to change groups		Group change (groups 2 and 3)*	        
Stop: not relevant to change groups				

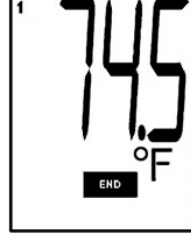

* Please see the summary table of the groups organization on the page 11.
** KH 120 only.

Device state	Type of start/stop selected	Button used	Action generated	Illustration
			Groups scrolling (groups 1, 2 and 3)*	  Or wait 3 seconds
Dataset finished END	There is no restart after the dataset has ended		Inactive	
			Measurements scrolling*	  

4.3.1 Groups organization

The table below summarizes the groups organization and measured values available during a measurement dataset.

	Group 1	Group 2	Group 3
Measured temperature		Max. value in temperature Min. value in temperature	High alarm threshold in temperature Low alarm threshold in temperature
Measured humidity**		Max. value in humidity** Min. value in humidity**	High alarm threshold in humidity** Low alarm threshold in humidity**

 →  →

 →

Press  to switch between groups.

Press  to select values in the scrolling group.

* Please see the summary table of the groups organization on this page.
 ** KH 120 only.

4.4 Data logger configuration with the on-board integrated PDF file

The class 120 data loggers have an on-board integrated PDF file for quickly and easily configuring the data logger. Therefore, you can directly configure your data logger without utilizing the KILOG software.

 **Required configuration:** to open this document, you need to use **ONLY** the “**Adobe Acrobat Reader 9®**” program (or higher), freely downloadable, to read PDF format documents. Ensure you have installed it before starting.

- Plug the class 120 data logger to the computer USB port*.

The following window opens:



- Click “**Open folder to view files**”.

Wait a few seconds (according to the dataset number of points), and a volume appears.

- Double-click “**Configuration...**” PDF file  configuration KT [1K 15.05.99999]

* The computer must be in compliance with the IEC60950 standard.

The integrated configuration file opens:

Header: indicates the name and serial number of the device.

Load a previous configuration, previously saved on the computer.

“General information”
Displays the name of the dataset and the possible comments.

“Configuration” setup:
- The datalogger
- The recording mode
- The stop conditions of the record

“Channel parameters” set up the temperature (KT 120 and KH 120) and hygrometry (KH 120 only) channels.

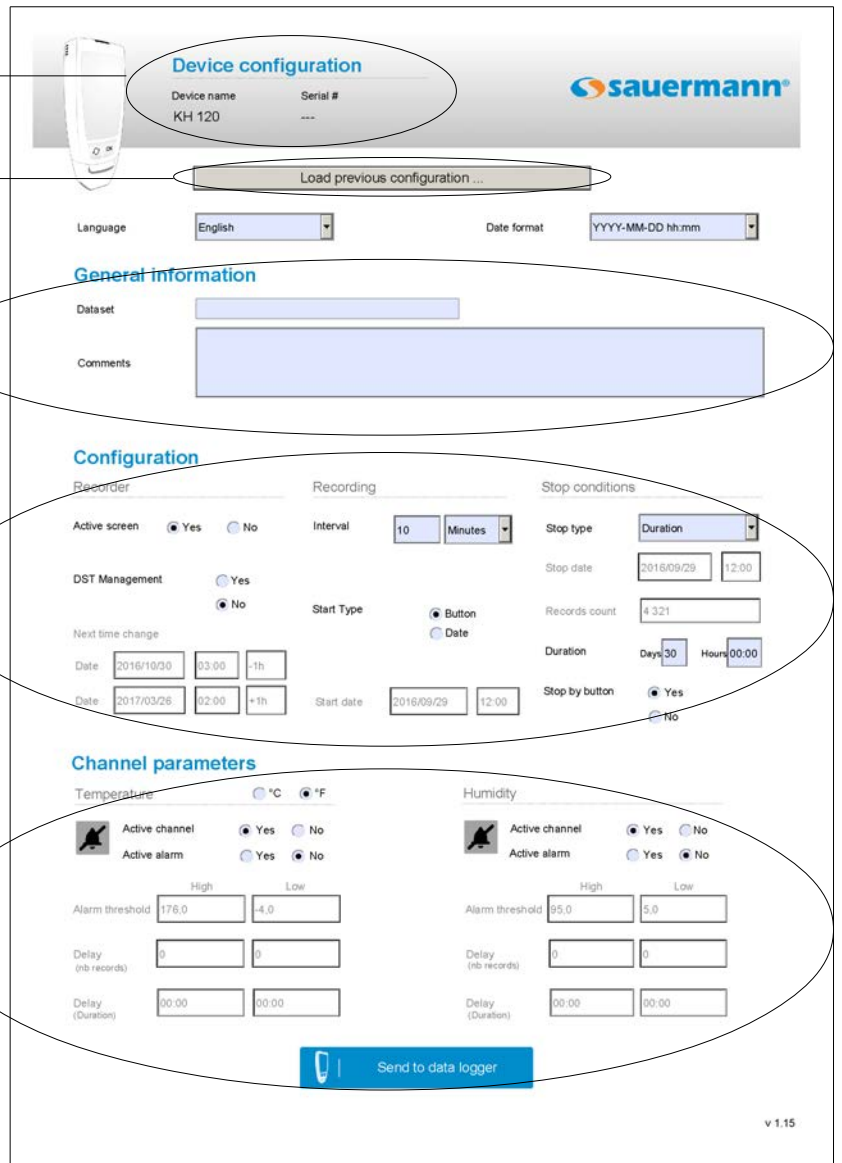

- **Language**

Select the desired language:

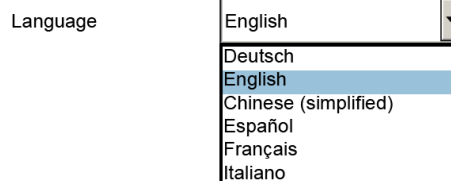

- **Date format**

Select the required date format:

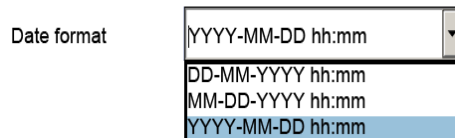

- **General information**

Dataset name: name the dataset.

Comments: write comments on dataset.



General information

Dataset	Dataset name
Comments	Comment 1 Comment 2

- **Configuration**

Recorder

Active screen: tick **"Yes"** to activate the screen display or **"No"** to deactivate it.

Management DST: for an automatic management of DST, tick **"Yes"** or tick **"No"** to deactivate it. If you choose **"Yes"**, the **"Next time change"** fields become accessible. Dates and times of the next time change are proposed by default. You can modify them: click **"Date"** field then  to display the calendar. Select the required date. Click **"Hour"** field to modify the time on which the next time change will be applied: the time format is 00:00. On the last field, click  and choose **"+1h"** to add an hour or **"-1h"** to subtract an hour. The date and time change will be applied on the required date and time and will add or subtract an hour.



Configuration

Recorder

Active screen Yes No

Management DST Yes No

Next time change

Date 2016/10/30 03:00 -1h

Date 2017/03/26 02:00 +1h

Recording

Interval: in the **"Interval"** field, enter the required interval duration between two measurements, then select the unit (minutes or hours).

Start type

- Tick **"Button"** for a start type by button.

- Tick **"Date"** for a start type by date: enter the required date and time of the start. Click **"Start date"** field then click  to display the calendar and select the required date, or write it manually, respecting the date format selected previously.

Recording

Interval 10 Minutes

Start Type Button Date

Start date 2016/09/01 12:00

Stop conditions

Stop type

Select the required stop type:

Stop type

Duration 

Date

Duration

Nbr of items

Total Memory

Loop

- The stop by date is available only if the start type by date has been previously chosen. If you choose **"Date"**, inform the required stop date and time in the **"Stop date"** field: click  to display the calendar then select the required date, or write it manually respecting the date format selected previously.

- Stop by duration: enter a recording duration. Fill in the **"Days"** and **"Hours"** fields.

- Stop by number of items: enter the required number of measurement before the dataset stops. Fill in the **"Number of items"** field (between 1 and 50 000 points).

- **"Total memory"**: record continuously up to 50 000 points before the dataset stops.

- **"Loop"** allows to record the values continuously and once the memory capacity is reached, the last recorded values overwrite the first.

- **"Stop by button"**: tick **"Yes"** to authorize a stop by button. Therefore, push the data logger **OK** button for 3 seconds to stop the measurement dataset. To not authorize it, tick **"No"**.

 The stop by button can not be deactivated if the chosen stop condition is **"Loop"**, **"Total memory"** or **"Number of points"**.



Stop conditions

Stop type Duration 

Stop date 2016/09/01 12:00

No. of items 4 321

Duration Days 30 Hours 00:00

Stop by button Yes No

Channel parameters

Temperature (KT 120 and KH 120) and humidity (KH 120 only)

- Choose the temperature measurement unit: tick the **"°F"** or **"°C"** box.

- Active channel: tick **"Yes"** to activate the channel or **"No"** to deactivate it.

- Active alarm: tick **"Yes"** to activate the alarm or **"No"** to deactivate it.

 Active channel Yes No

 Active alarm Yes No

Channel parameters

Temperature °C °F

 Active channel Yes No

 Active alarm Yes No

Alarm threshold High 176,0 Low -4,0

Delay (nb pts) 0 0

Delay (Duration) 00:00 00:00

If the alarm is activated, fill in the **"High"** and **"Low"** fields to set the alarm threshold. Inform the **"Delay"** field in number of points. According to the measurement interval previously configured, the duration is automatically actualized. Example for a setting with an interval of 1 minute and a delay in number of points for the high threshold of 5: the delay duration will be 5

minutes.

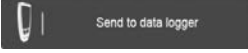
- When the configuration is complete, click  to confirm.
- Chose the location to save the configuration: to use this configuration for the next dataset, save the configuration directly on the data logger on **"Removable disk"**.

 **Check that the dataset is completed to ensure the new configuration will be taken into account.**

A message will ask to overwrite the existing file.

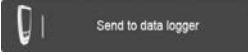
- Click **"Yes"**.
- To use this configuration later for another dataset, or to configure another device, you can save it on the computer. To recover it later, click  then select the file under **".xdp"** format,click  to use it with the next dataset.

4.5 Data logger download with PDF report edition

- Plug the class 120 data logger to the computer USB port*.

Wait a few seconds, then the following window will open:



- Click **"Open folder to view files"**.

The windows explorer opens.



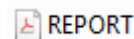

- Double-click **"Report"** PDF file to visualize the dataset report.



* The computer must be in compliance with the IEC60950 standard.

Example of report:

State indicators:

-  : Alarm activated
-  : Alarm deactivated
-  : Alarm OK
-  : Alarm triggered

Background information:

dataset name and possible comments.

Device configuration:

measurement interval, start/stop type, recording duration, number of recorded values, date and time of dataset start and end.

Chart: visualize the recorded values evolution, with the units on ordinate, the date and time on abscissa and the defined high and low thresholds.

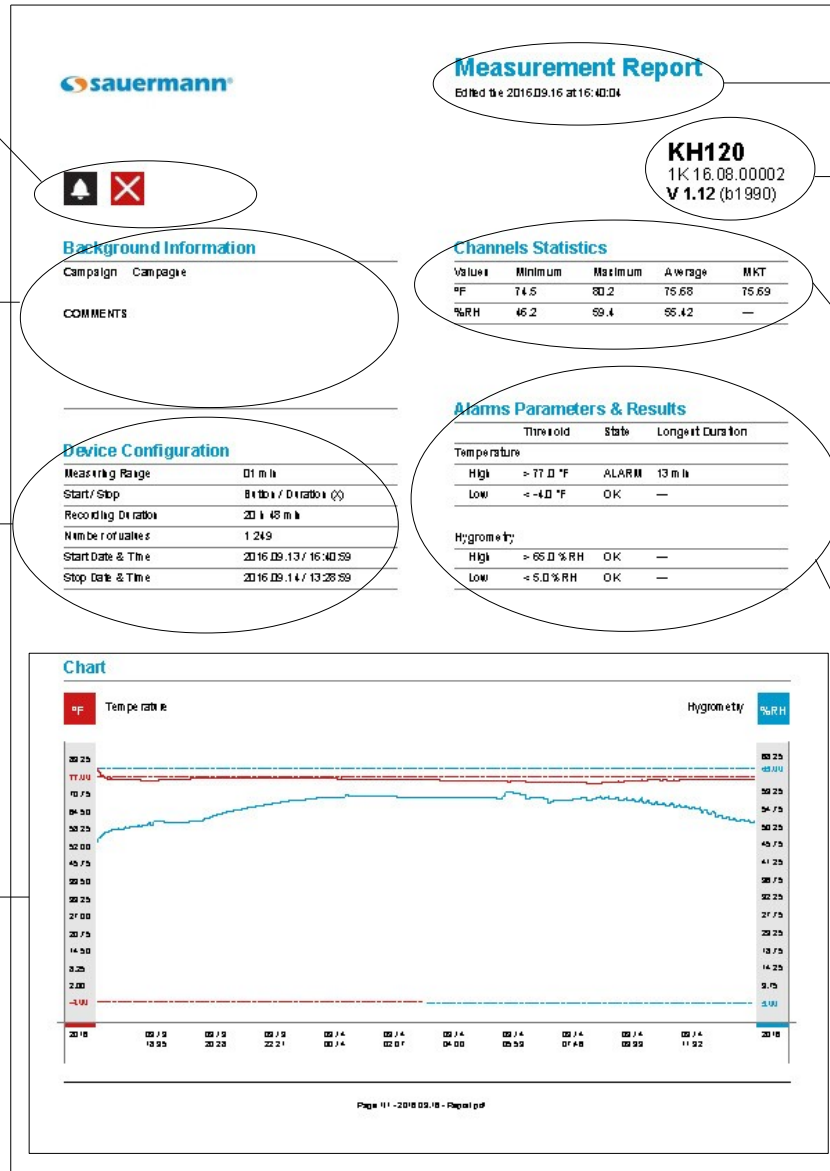

Header: date and time of the report edition

Device references
Serial number and firmware version

Channel statistics:
values unit, minimum, maximum, average and MKT values.

Alarms parameters & results: defined high and low thresholds, their state (alarm or OK) and longest duration of exceeded threshold.

➤ Print it or export this report as a PDF file.

5 DEVICE MAINTENANCE

5.1 Replace the battery

With 500 days to 3 years* battery life, the data logger guarantees long-term measurement.

To replace the battery:

1. Unlock the battery hatch with a flathead screwdriver or a coin.
2. Turn left until the marker aligns in front of the opened padlock symbol.
3. Keep turning until the hatch rises.
4. Replace the battery (button battery CR 2450**) in such a way the + pole is visible.

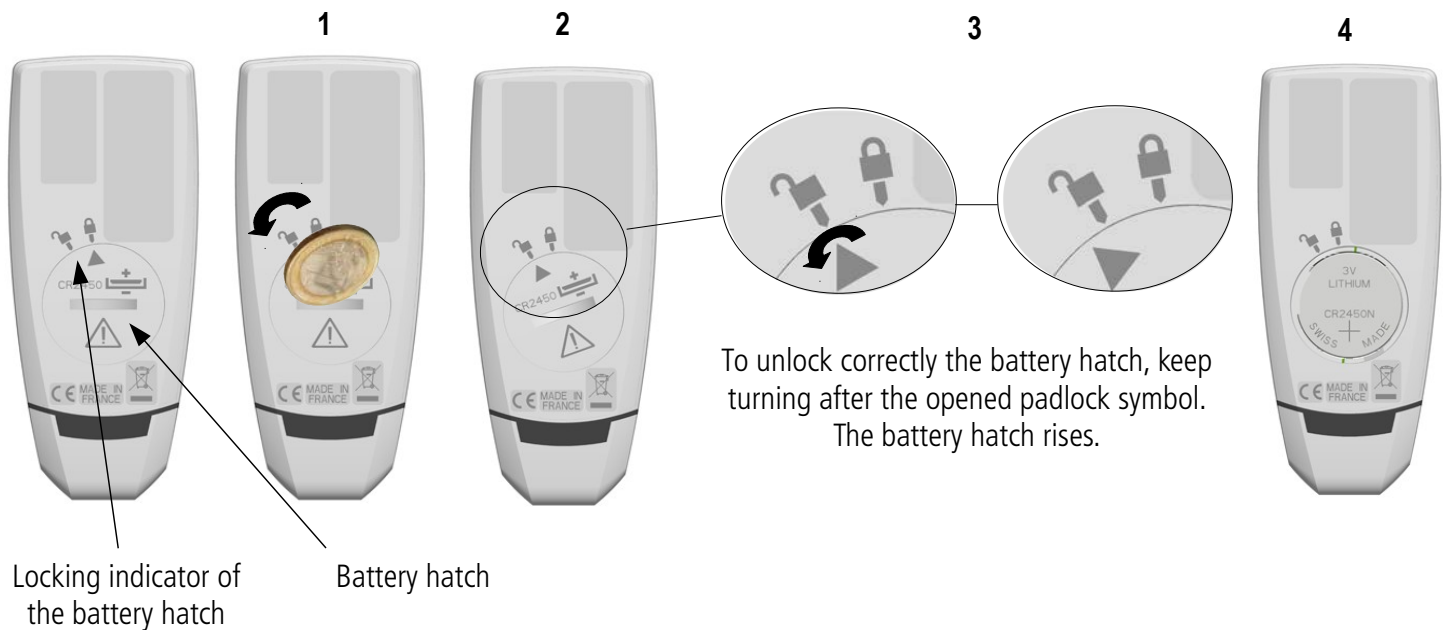

- Replace the battery hatch with the indicator in front of the opened padlock and close it by turning it towards the right, in order to match the indicator with the closed padlock.



Only use trademark or high quality batteries in order to guarantee proper battery life.



After the battery replacement, the device must be reconfigured.

5.2 Device cleaning

Please avoid any aggressive solvent.

Please protect the device from any cleaning product containing formaldehyde that may be used to clean rooms and ducts.

* On the basis of 1 measurement each 15 minutes at 77°F (25°C).

** The battery must be in compliance with the IEC60086-4 standard.





6 CALIBRATION

All the data loggers have an integrated adjustment certificate (as a PDF file).

Calibration certificates are available (contact Sauer mann office for more information).

We recommend annual calibration.

7 ACCESSORIES

Part No.	Description	Image
KILOG-LITE	Free basic software for configuration, and data download (tabular & graphical). Available for download at www.sauer mann.us/data-logger	
KILOG-3-N	Premium software for configuration, data download, and fast and easy data saving, processing, and calculations. Available for download at www.sauer mann.us/data-logger	
KBL-2450	1 CR2450 battery	
KRM	0.98" (25 mm) diameter metal washer with double sided adhesive tape	



Recommended accessories to be used with data loggers

8 TROUBLESHOOTING

Problem	Probable cause and possible solution
"hi" or "lo" is displayed.	The measurement range is exceeded. There is a problem with the sensing element.
No value is displayed, only the icons are present.	The display is set " OFF ". Set it on " ON " with the KILOG software (see page 9).
The display is completely off and there is no communication with the computer.	The battery must be replaced (see page 17).



BE CAREFUL! Material damages can happen, so please apply the precautionary measures indicated.