

REED

Model R5600

Digital Insulation Tester



Instruction Manual

1-877-849-2127 | info@reedinstruments.com

www.reedinstruments.com

Table of Contents

Safety	3
Specifications.....	4-5
<i>General</i>	4
<i>Electrical</i>	5
Meter Description.....	6
Operating Instructions.....	6-7
<i>How to connect the test leads</i>	6
<i>How to check the test leads</i>	7
<i>Battery replacement</i>	7
Measurements.....	7-8
<i>Insulation Resistance Measurements</i>	7
<i>Low Resistance Measurements</i>	8
<i>AC/DC Voltage Measurements</i>	8
Power Tool & Small Appliances.....	9-10
<i>Motors</i>	9
<i>Cables</i>	10

For service on this or any other REED product, contact REED Instruments at info@reedinstruments.com.

1-877-849-2127 | info@reedinstruments.com

www.reedinstruments.com

Safety

- Read the following safety information carefully before attempting to operate or service the meter.
- To avoid damages to the instrument do not apply the signals which exceed the maximum limits shown in the technical specifications tables.
- Do not use the meter or test leads if they look damaged. Use extreme caution when working around bare conductors or bus bars.
- Accidental contact with the conductor could result in electric shock.
- Use the meter only as specified in this manual; otherwise, the protection provided by the meter may be impaired.
- Read the operating instructions before use and follow all safety Information.
- Caution when working with voltages above 60V DC or 30V AC RMS. Such voltages pose a shock hazard.
- Before taking resistance measurements or testing acoustic continuity, disconnect circuit from main power supply and all loads from the circuit.

Safety Symbols:



Caution

Refer to this manual before using the meter.



Dangerous voltages.



Meter is protected throughout by double insulation or reinforced insulation.

When servicing, use only specified replacement parts.

CE Comply with EN-61010-1

For service on this or any other REED product, contact REED Instruments at info@reedinstruments.com.

1-877-849-2127 | info@reedinstruments.com

www.reedinstruments.com

Specifications

General Specifications

Environment conditions

- Installation Categories II
- Pollution Degree 2
- Altitude up to 2000 meters
- Indoor use only
- Relatively humidity 80% max.
- Operation Ambient 0~40°C

Maintenance & Cleaning

- Repairs or servicing not covered in this manual should only be performed by qualified personnel.
- Periodically wipe the case with a dry cloth. Do not use abrasives or solvents on this instruments.

Display:	Large LCD with dual display
Measurement Range:	200Ω, 200kΩ, 200MΩ/250V, 200MΩ/500V, 2000MΩ/1000V, 750V/ACV, 1000V/DCV.
Sampling Rate:	2.5 times per second.
Zero Adjustment:	Automatic adjustment.
Over Range Indicator:	Number 1 of highest digit is displayed.
Low Battery Indication:	The  is displayed when the battery voltage drops below the operating voltage.
Operating Temperature:	0°C to 40°C (32°F to 104°F) and Humidity below 80% RH
Storage Temperature:	-10°C to 60°C (14°F to 140°F) and Humidity below 70% RH
Power source:	DC 9V (6 x 1.5V Size “AA” battery or equivalent)
Dimensions:	200(L) x 92(W) x 50(H) mm
Weight:	Approx 700g including the batteries
Contents:	Test leads, 6 batteries, carrying case and manual

Electrical Specifications

Accuracies are specified by:

$\pm(\dots\%$ of reading + \dots digits) at $23^{\circ}\text{C}\pm 5^{\circ}\text{C}$, below 80% RH.

OHMS				
Range	Resolution	Accuracy	Max. open Circuit Voltage	Overload Protection
200 Ω	0.1 Ω	$+(1\%+2)$	4.5V	250Vrms
200k Ω	0.1k Ω		3.0V	
Continuity Beeper				
Range	Resolution	Operation Resistance	Max.open Circuit Voltage	Overload Protection
•)))	0.1 Ω	Resistance $\leq 40\Omega$	4.5V	250Vrms
Short circuit current:		$\leq 200\text{mA}$		
DC Voltage				
Range	Resolution	Accuracy	Input Impedance	Overload Protection
1000V	1V	$+(0.8\%+3)$	10M Ω	1000Vrms
AC Voltage (40Hz~400Hz)				
Range	Resolution	Accuracy	Input Impedance	Overload Protection
750V	1V	$+(1.2\%+10)$	10M Ω	750Vrms
Meg OHMS				
Range	Resolution	Accuracy	Terminal Voltage	
200M Ω /250V	0.1M Ω	$+(3\%+5)$	250V+10%~-0%	
200M Ω /500V	0.1M Ω		500V+10%~-0%	
0~1000M Ω /1000V	1M Ω	$+(5\%+5)$	1000V+10%~-0%	
1000~2000M Ω /1000V				
Range	Test Current		Short circuit current	
200M Ω /250V	1mA	250K Ω (load)	$\leq 1\text{mA}$	
200M Ω /500V		500K Ω (load)		
0~1000M Ω /1000V		1M Ω		
1000~2000M Ω /1000V				

Meter Description

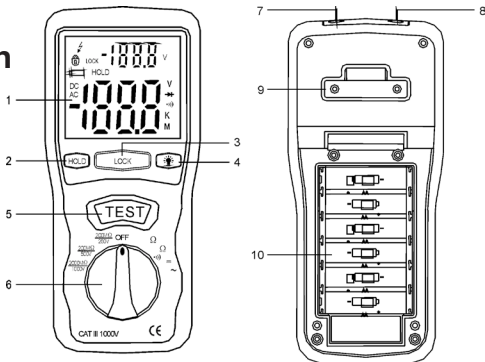

- 1 — Digital Display
- 2 — Data Hold Button
- 3 — Lock Button
- 4 — Backlight Button
- 5 — Test Button
- 6 — Rotary Function switch
- 7 — VΩ Jack
- 8 — COM input jack
- 9 — Pothook
- 10 — Battery Cover

Operating Instructions

How to connect test leads

1. On MΩ Range: Connect the red test lead into the “VΩ” terminal and the black lead into the “COM” terminal.
2. On 200Ω and ACV Range: Connect the red test lead into the “VΩ” terminal and the black lead into terminal “COM”

How to check the test leads

Set the range select switch to the 200Ω range. With the tip and alligator clip of the test leads connected, the indicator should read 00.0Ω. When the leads are not connected the display will read infinity indicated by “1”. This will ensure that test lead are under working condition.

Battery Replacement

1. When the battery power is not sufficient the LCD will display .
2. Replacement of 6 new batteries, type 1.5V size “AA” is required.
3. Once replaced be sure to reinstall the battery cover and the four screws before operating.

Measurements

Insulation Resistance Measurements

Measurements at 200M Ω /250V

This is the voltage used for the majority of insulation resistance tests on normal installation requirements. To measure insulation resistance, press the test button to turn on the tester.

The LCD will display the insulation resistance. Section VII indicated that subdivision of large installations might be necessary because of the large number of parallel insulation resistance. In such a case, an installation may be divided into sections, each being separately tested. Each section must have at least fifty outlets, an outlet being a switch, socket, lighting point etc. A switched socket counts as one outlet. The minimum acceptable insulation resistance is 1M Ω .

For a large installation, the capacitance of the insulation will be high, and it will take longer for it to become charged by the direct testing voltage. Be careful not to take a reading until there is a steady reading, indicating that the charging process is complete.

Note: The charge stored in the insulation will be discharged automatically when the test button is released. Be careful not to turn the range switch knob while the test button is pressed, or the instrument will be damaged.

Measurements at 2000M Ω /1000V

Some specifications require testing at 1000V. This voltage must also be selected where the supply voltage of the installation is between 500V and 1000V. First, set the range switch to 1000V and then proceed as indicated in above for 500V testing.

The above note also applies to testing at 1000V. In addition the following applies.

continued

Note: Make sure that the circuit under does not include components Which will be damaged by the 1000V applied. Many normal components of an installation are likely to be damaged if tested at 1000V. Examples are power factor correction capacitors, low voltage mineral insulated cables, electronic light dimmers, electronic ballasts and starters for fluorescent lamps etc...

Lock Power on Feature

For hands free operation a lock power on feature is incorporated in the press to test button. Set the LOCK button to lock test voltage, pressing it again will turn the tester off.

Low Resistance (Continuity) Measurements

1. Set the range switch to 200 Ω •))) Position
2. Connect the red test lead to the V Ω terminal and back to the COM terminal.
3. Connect the tips of the test leads to both ends of the circuit under test. Read resistance in Ω on the LCD.
4. When the impedance on circuit is below approximately 40 Ω . It will indicate by a continuous beeper.

AC/DC Voltage Measurements

1. Set the range switch to ACV or DCV position
2. Connect red test lead to “V Ω ” terminal and black test lead to terminal “COM”.
3. Connect test prods of test leads IN PARALLEL to the circuit being measured.
4. Read the voltage value on LCD.

Power Tools & Small Appliances

This test would also apply to other similar equipment that has a line cord. For double insulated power tools, the megohmmeter lead shown (See graphic on page 8) connected to the housing would be connected to some metal part of the tool (ie: chuck, blade).

Note: The switch of the device must be in the "ON" position and the main power should be disconnected.

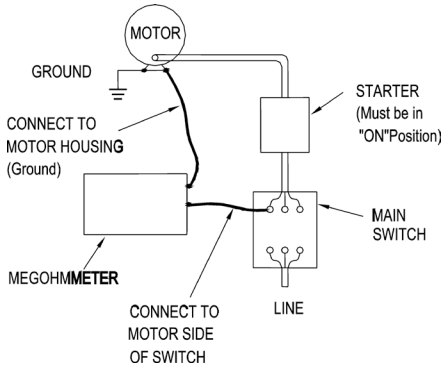

Motors

AC-Disconnect the motor from the line by disconnecting the wires at the motor terminals or by opening the main switch. If the main switch is used and the motor also has a starter then the starter must be held, by some means, in the "ON" position. In the latter case, the measured resistance will include the resistance of the motor, wire and all other components between the motor and the main switch. If a weakness is indicated, the motor and other components should be checked individually. If the motor is disconnected at the motor terminals, connect one megohmmeter lead to the grounded motor housing and the other lead to One of the motor leads. DC-Disconnect the motor from the line. To test the brush rigging, field coils and armature connect one megohmmeter lead to the grounded motor housing and the other lead to the brush on the commutator. If the resistance measurement indicates a weakness, raise the brushes off the commutator and separately test the armature, field coils and brush rigging by connecting one megohmmeter lead to each of them individually, leaving the other connected to the grounded motor housing. The above also applies to DC Generators.

Cables

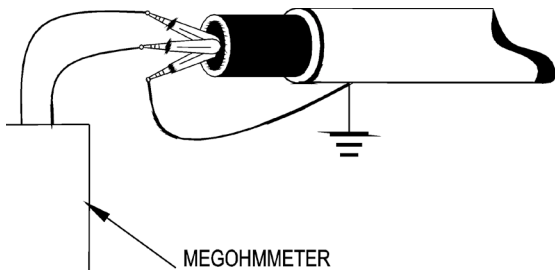

Disconnect the cable from the line. Also disconnect opposite end to avoid errors due to leakage from other equipment. Check each conductor to ground and /or lead sheath by connecting one megohmmeter lead to a ground and /or lead sheath and the other megohmmeter lead to each of the conductors in turn. Check insulation resistance between conductors by connecting megohmmeter leads to conductors in pairs.

For service on this or any other REED product, contact REED Instruments at info@reedinstruments.com.

1-877-849-2127 | info@reedinstruments.com

www.reedinstruments.com

Notes
