

R2310

REED INSTRUMENTS

Infrared Thermometer



Instruction Manual

REED Instruments

1-877-849-2127 | info@reedinstruments.com | www.reedinstruments.com

Table of Contents

Introduction	3
Product Quality.....	3
Safety	3
Features.....	4
Included.....	4
Specifications	4-5
Instrument Description	6
Display Description	7
Distance & Spot Size.....	8
Operating Instructions.....	9-13
<i>Power ON and OFF</i>	9
<i>Manual Measurement</i>	9
<i>Continuous Temperature Measurement (Trigger Lock)</i>	9
<i>Maximum, Minimum, Average and Differential Functions</i>	10
<i>Setting the High Temperature Alarm</i>	10
<i>Setting the Low Temperature Alarm</i>	11
<i>Adjusting Emissivity</i>	11
<i>Switching the Unit of Measure (°F/°C)</i>	12
<i>Turning Laser ON/OFF</i>	12
<i>Trigger Lock Setup</i>	12
<i>Turning High and Low Alarms ON/OFF</i>	13
Battery Replacement.....	14
Applications.....	14
Appendix: Emissivity Chart	15-16
Product Care	17
Product Warranty	17
Product Disposal and Recycling	17
Product Support.....	18

Introduction

Thank you for purchasing your REED R2310 Infrared Thermometer. Please read the following instructions carefully before using your instrument. By following the steps outlined in this manual your meter will provide years of reliable service.

Product Quality

This product has been manufactured in an ISO9001 facility and has been calibrated during the manufacturing process to meet stated product specifications. If a certificate of calibration is required please contact the nearest authorized REED distributor or authorized Service Center. Please note an additional fee for this service will apply.

Safety

- Never attempt to repair or modify your instrument. Dismantling your product, other than for the purpose of replacing batteries, may cause damage that will not be covered under the manufacturer's warranty. Servicing should only be provided by an authorized service center.
- Use extreme caution when the laser beam is turned on.
- Do not let the beam enter your eye, another person's eye or the eye of an animal.
- Be careful not to point the beam off a reflective surface and strike your eye.
- Do not allow the laser light beam to impinge on any gas which can explode.

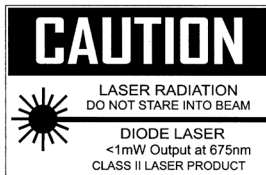

Features

- Built-in laser pointer identifies target area
- User selectable °F or °C
- 12:1 distance to spot size ratio
- Digitally adjustable emissivity
- Max, Min, Average and Differential readings
- Backlit display
- High and low alarms
- Dustproof and Drop tested
- Trigger lock for continuous monitoring
- Low battery indication and auto shut off

Included

- Carrying Case
- Battery

Specifications

Temperature Range:	-31 to 1202°F (-35 to 650°C)
Accuracy:	≥32°F (0°C):±3.6°F (1.8°C) or ±1.8% rdg., whichever is greater <32°F (0°C):±3.6°F+0.1°F (1.8°C+0.1°C)/rdg.
Resolution:	0.1°F (0.1°C)
Optical Resolution (D:S):	12:1
Spectral Response:	8 to 14µm
Emissivity:	0.1 to 1.0 (Adjustable)
Response Time:	250ms
Backlit Display:	Yes
Display Hold:	Yes
High/Low Alarms:	Yes
Alarm Indicators:	LED (High: Red, Low: Blue)

continued...

REED Instruments

1-877-849-2127 | info@reedinstruments.com | www.reedinstruments.com

Max/Min:	Yes
Average and Differential:	Yes
F/C Switchable:	Yes
Trigger Lock:	Yes
Tripod Mountable:	Yes
Drop Tested:	Yes, 9.8' (3M)
Laser Type:	Class II
Low Battery Indicator:	Yes
Power Supply:	9V battery
Battery Life:	Approx. 10 hours (with continuous use, backlight on)
Product Certifications:	CE, RoHS, IP65, Drop Tested
Operating Temperature:	32 to 122°F (0 to 50°C)
Storage Temperature:	-4 to 140°F (-20 to 60°C)
Operating Humidity Range:	10 to 90%
Maximum Operating Altitude:	6561' (2000m)
Maximum Storage Altitude:	39370' (12000m)
Dimensions:	7.4 x 4.7 x 2.2" (189 x 118 x 55mm)
Weight:	10.3oz (292g)

Instrument Description

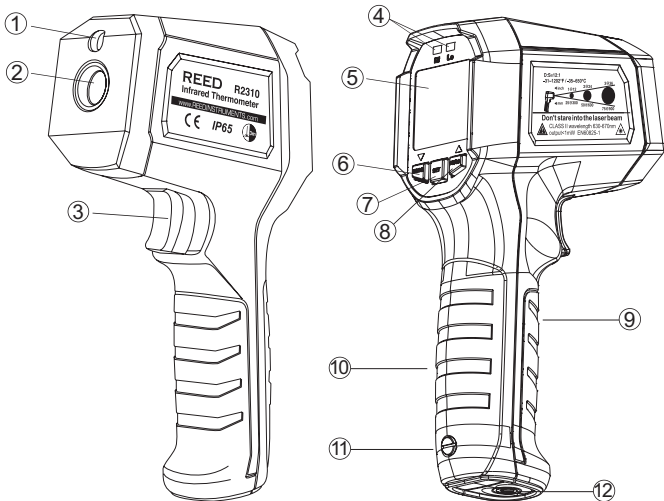



1. Laser Pointer Beam
2. IR Sensor
3. Trigger
4. High/Low Alarm Indicators
5. LCD Display
6. Mode Button/Down Arrow
7. Set Button
8. High/Low Alarm Button/
Up Arrow
9. Handle Grip
10. Battery Cover
11. Battery Compartment Screw
12. Tripod Mount

REED Instruments

1-877-849-2127 | info@reedinstruments.com | www.reedinstruments.com

Display Description



	Temperature Measurement Trigger Lock
	Laser ON
HI LO	High and Low Limit Alarm
	Low Battery
SCAN	Temperature Measurement Active
HOLD	Measurement Data Hold
°F °C	Unit of Measurement
8888	Temperature Measurement Value
MAX MIN AVG DIF	Mode
ε = 0.88	Emissivity
8888	Temperature Measurement Value from Selected Mode

Distance & Spot Size

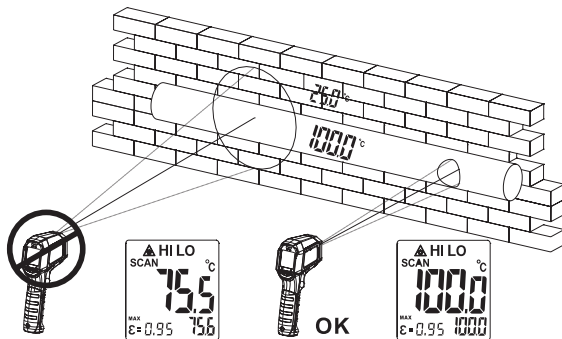
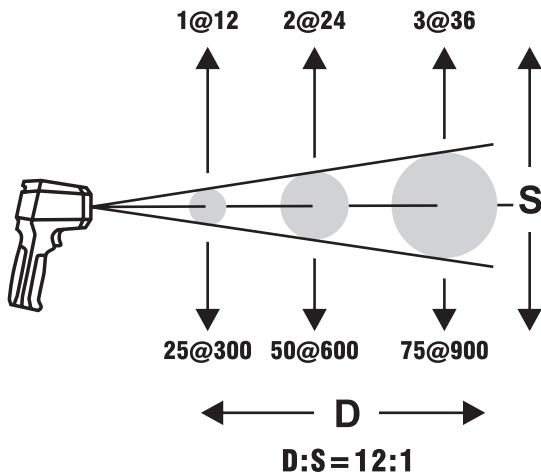

REED Instruments

1-877-849-2127 | info@reedinstruments.com | www.reedinstruments.com

Operating Instructions



Power ON and OFF

1. Gently pull the trigger to turn the thermometer on. The LCD display and white backlight will turn on.
2. The thermometer will automatically shut off after 8 seconds of inactivity.

Manual Measurement

1. Pull and hold the trigger after aiming at the target. The **SCAN** icon will flash, indicating that the target temperature is being measured.
2. When the trigger is released, the **SCAN** icon will disappear and the **HOLD** icon will appear indicating that measurement has stopped and the last measured temperature will remain on-screen until another measurement is taken or the unit turns off.

Continuous Temperature Measurement (Trigger Lock)

1. Once the trigger lock function is enabled (see page 12), the  icon will appear on the display and the **SCAN** icon will flash when the trigger is pressed. The thermometer will continuously measure temperature and the backlight will auto shut off after 2 minutes.
2. Pull the trigger again to stop measuring and the  and **SCAN** icons will disappear and the **HOLD** icon will appear. The thermometer will keep the last measured value until the unit turns off.

continued...

Maximum, Minimum, Average and Differential Functions

Press the **MODE** button to toggle between MAX/MIN/AVG/DIF modes. The temperature value of corresponding modes are shown in the secondary display area.

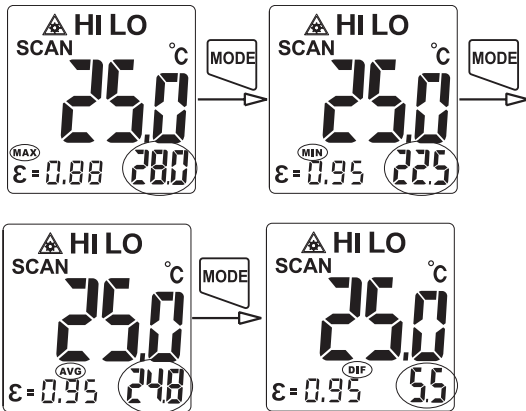

Setting the High Temperature Alarm

Press the **SET** button once to enter the high alarm limit setup. Use the **UP** and **DOWN** buttons to set temperature value. Press the **UP** and **DOWN** buttons to add or subtract 1. Hold the **UP** or **DOWN** buttons to add or subtract 10 temperature values. The instrument will exit the setup after 5 seconds of inactivity.

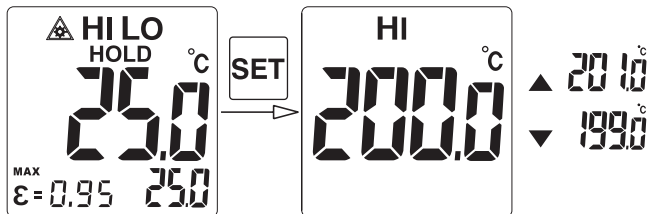

continued...

REED Instruments

1-877-849-2127 | info@reedinstruments.com | www.reedinstruments.com

Setting the Low Temperature Alarm

Press the **SET** button twice to enter the low alarm limit setup. Use the **UP** and **DOWN** buttons to set values. Press the **UP** and **DOWN** buttons to add or subtract 1 temperature value. Hold the **UP** or **DOWN** buttons to add or subtract 10 temperature values. The instrument will exit the setup after 5 seconds of inactivity.

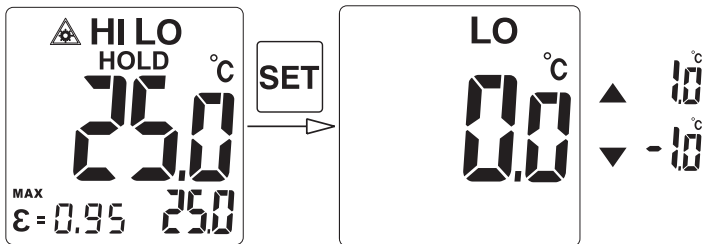

Adjusting Emissivity

The instrument's emissivity can be adjusted from 0.01 to 1.0. Press the **SET** button three times to enter the emissivity setup. Use the **UP** and **DOWN** buttons to set the values. Press the **UP** and **DOWN** buttons to add or subtract 0.01 unit and/or hold the **UP** and **DOWN** buttons to add or subtract 0.1. The thermometer will exit the setup after 5 seconds of inactivity.

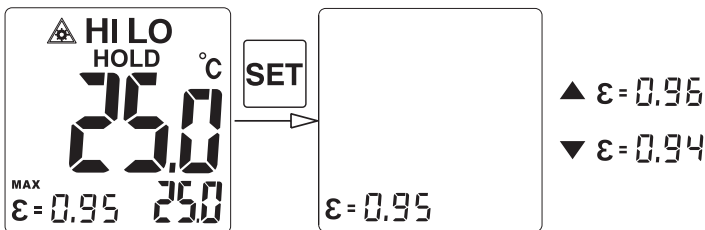

continued...

REED Instruments

1-877-849-2127 | info@reedinstruments.com | www.reedinstruments.com

Switching the Unit of Measure (°F/°C)

Press the **SET** button four times to enter unit of measure setup. Use the **UP** and **DOWN** buttons to switch between °F and °C units. The thermometer will exit the setup after 5 seconds of inactivity.

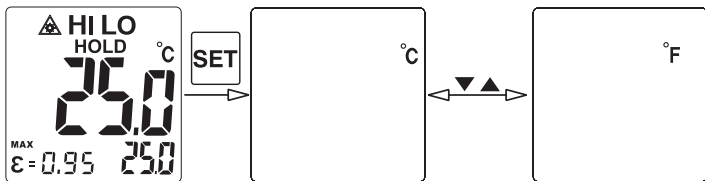

Turning Laser ON/OFF

To turn the laser on or off, press the **SET** button five times to enter laser setup. Use the **UP** and **DOWN** buttons to turn the laser on or off. The thermometer will exit the setup after 5 seconds of inactivity.

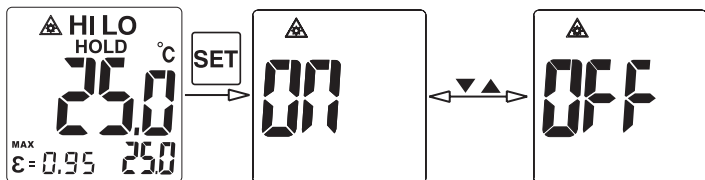

Trigger Lock Setup

To turn the lock measurement on or off, press the **SET** button six times to enter lock measurement setup. Use the **UP** and **DOWN** buttons to feature on or off. The thermometer will exit the setup after 5 seconds of inactivity.

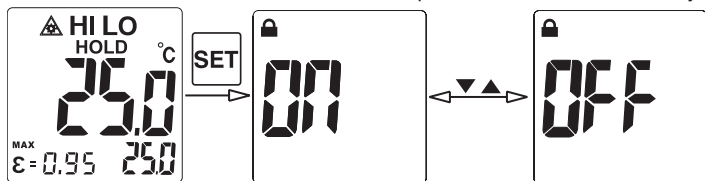

continued...

REED Instruments

1-877-849-2127 | info@reedinstruments.com | www.reedinstruments.com

Turning High and Low Alarms ON/OFF

Press the **HI LO** button to enter alarm setup screen. Press the **HI LO** button again to toggle through the alarm functions.

1. High/Low alarms on.
2. High alarm on.
3. Low alarm on.
4. No alarm set.

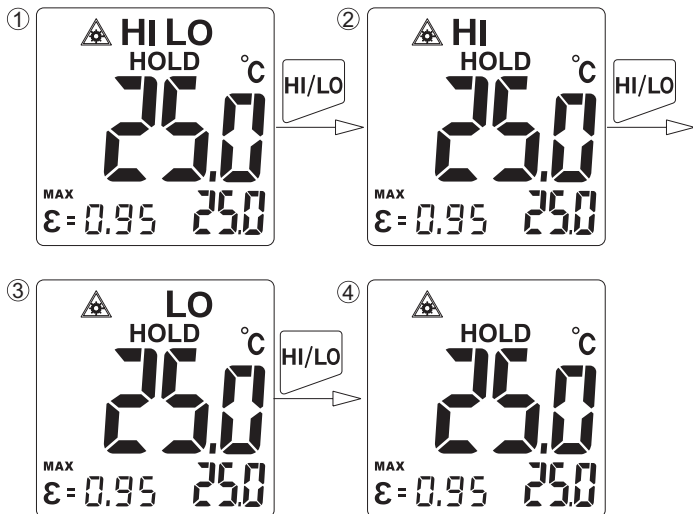

Battery Replacement

1. The battery should be replaced when  is displayed.
2. Remove the screw with a flat screwdriver and open the battery cover.
3. Replace the 9V battery.
4. Place the battery cover back and tighten the screw.

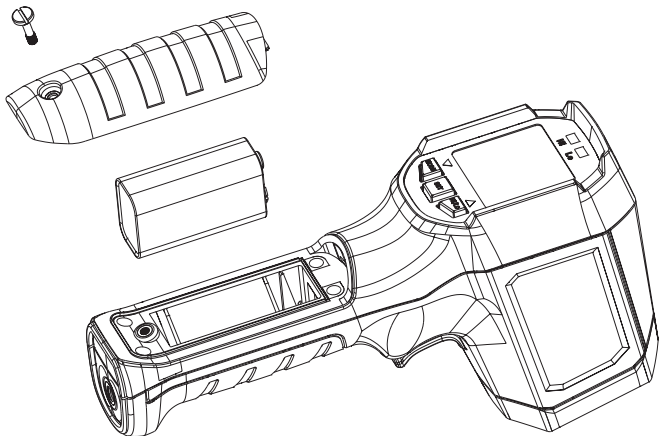

Applications

- Verify mechanical (bearings, motors) or electrical (circuit breaker boxes) equipment
- Calibration and control of heater and oven temperatures
- Monitoring materials in processes involving heating and/or cooling
- Quality control monitoring
- Research and development applications
- Automotive diagnostics
- Conduct HVAC energy audits

REED Instruments

1-877-849-2127 | info@reedinstruments.com | www.reedinstruments.com

Appendix: Emissivity Chart

Emissivity is a term used to describe the energy-emitting characteristics of materials. Most (90% of typical applications) organic materials and painted or oxidized surfaces have an emissivity of 0.95.

Inaccurate readings will result from measuring shiny or polished metal surfaces. To compensate, cover the surface to be measured with masking tape or flat black paint. Allow time for the tape to reach the same temperature as the material underneath it. Measure the temperature of the tape or painted surface.

Measured Surfaces	Emissivity
Metal	
Aluminum: Oxidization	0.2-0.4
A3003 Alloy: Oxidization, Rough	0.3, 0.1-0.3
Brass: Burnishing, Oxidization	0.3, 0.5
Copper: Oxidization, Electric Terminal Board	0.4-0.8, 0.6
Hastelloy: Alloy	0.3-0.8
Inconel: Oxidization, Sand-Blasting, Electro Burnishing	0.7-0.95, 0.3-0.6, 0.15
Iron: Oxidization, Rusting	0.5-0.9, 0.5-0.7
Iron (Casting): Oxidization, Non-Oxidization, Casting	0.6-0.95, 0.2, 0.2-0.3
Iron (Forging): Passivation	0.9
Lead: Rough, Oxidization	0.4, 0.2-0.6
Molybdenum: Oxidization	0.2-0.6
Nickel: Oxidization	0.2-0.5
Platinum: Black	0.9

continued...

Steel: Cold Rolling, Steel Plate Burnishing, Steel Plate Rubbing	0.7-0.9, 0.4-0.6, 0.1
Zinc: Oxidization	0.1
Non-Metal	
Asbestos	0.95
Asphalt	0.95
Basalt	0.7
Carbon: Non-Oxidization, Graphite, Silicone Carbide	0.8-0.9, 0.7-0.8, 0.9
Ceramics	0.95
Clay	0.95
Concrete	0.95
Cloth	0.9
Glass: Convex, Smooth, Lead-Boron	0.76-0.8, 0.92-0.94, 0.78-0.82
Plates	0.96
Stone Products	0.93
Plaster	0.8-0.95
Ice	0.98
Limestone	0.98
Paper	0.95
Plastics	0.95
Water	0.93
Soil	0.9-0.98
Wood	0.9-0.95

Product Care

To keep your instrument in good working order we recommend the following:

- Store your product in a clean, dry place.
- Change the battery as needed.
- If your instrument isn't being used for a period of one month or longer please remove the battery.
- Clean your product and accessories with biodegradable cleaner. Do not spray the cleaner directly on the instrument. Use on external parts only.

Product Warranty

REED Instruments guarantees this instrument to be free of defects in material or workmanship for a period of one (1) year from date of shipment. During the warranty period, REED Instruments will repair or replace, at no charge, products or parts of a product that proves to be defective because of improper material or workmanship, under normal use and maintenance. REED Instruments total liability is limited to repair or replacement of the product. REED Instruments shall not be liable for damages to goods, property, or persons due to improper use or through attempts to utilize the instrument under conditions which exceed the designed capabilities. In order to begin the warranty service process, please contact us by phone at 1-877-849-2127 or by email at info@reedinstruments.com to discuss the claim and determine the appropriate steps to process the warranty.

Product Disposal and Recycling



Please follow local laws and regulations when disposing or recycling your instrument. Your product contains electronic components and must be disposed of separately from standard waste products.

REED Instruments

1-877-849-2127 | info@reedinstruments.com | www.reedinstruments.com

Product Support

If you have any questions on your product, please contact your authorized REED distributor or REED Instruments Customer Service by phone at 1-877-849-2127 or by email at info@reedinstruments.com.

Please visit www.REEDINSTRUMENTS.com for the most up-to-date manuals, datasheets, product guides and software.

*Product specifications subject to change without notice.
All rights reserved. Any unauthorized copying or reproduction of this manual is strictly prohibited without prior written permission from REED Instruments.*