

APN-R SERIES

Power Monitor

The APN -R Series Power Monitor measures three phases of current and voltage and computes fourteen values necessary to track power usage. The monitor uses flexible current sensors to measure the amperes, and the line voltage connects directly to the transducer, up to 600 VAC. The result is 14 data points in the RS485 Modbus RTU format. There is also a pulse contact which opens and closes as watt hours are accumulated. The APN-R is factory configured with specifically matched flexible coils. The ease of installation over multiple conductors or bus assemblies will speed installation and produce an accurate set of data to help you identify areas of excessive energy consumption and allow intervention to reduce demand.



Power Sensing Applications

Plant Energy Management

- Measure the power usage of a single piece of equipment, an area of a plant, or the entire facility.

Conveyors

- Detect jams and overloads.
- Check that the belt is loaded properly by measuring the power consumption.

Pump Monitoring

- Detect dry run from clogged, intake, or discharge line.
- Monitor impeller cavitation and bearing wear.

Pump Jam & Suction Loss Protection

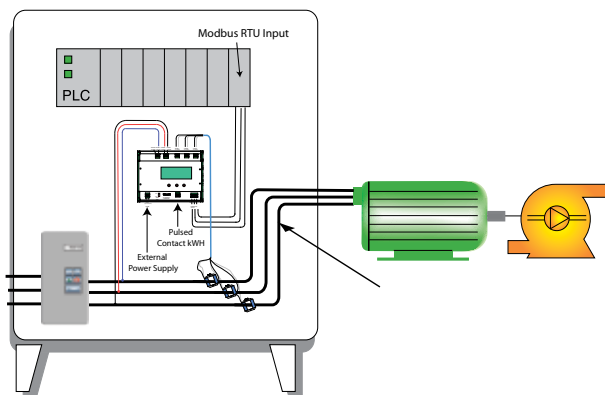

Power Sensing Features

Modbus RTU Output

- RS485 communication protocol reduces the cost involved with proprietary data logging software.
- Compatible with most automation systems.

Externally Powered

- Improves reliability when used in conditions where power interruptions and voltage sags are common.

Compact DIN Mounted Housing

- Clearly labeled terminals provide quick installation.
- Low profile reduces cabinet depth requirements.

LED Displays Network Communication

- Provides quick visual indication that network is operational.

Finger Safe Terminals

- Safe and secure connectors.

Designed to Meet UL, CUL and CE Approval

- Accepted worldwide.

Test & Evaluation Units
For OEMs Free program expedites evaluation process.
 See page 1 for details.



Power Sensing Dimensions

Case Side View

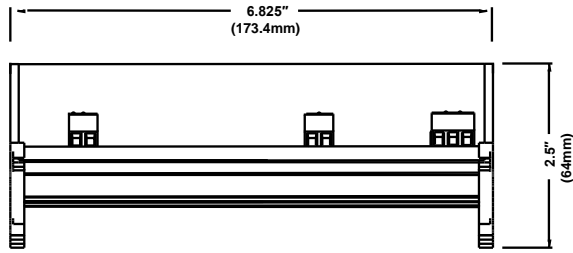

Case Top View

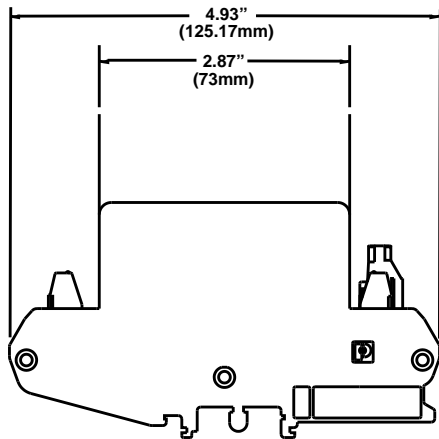

Note: Drawings are not to scale.

Power Sensing Connections

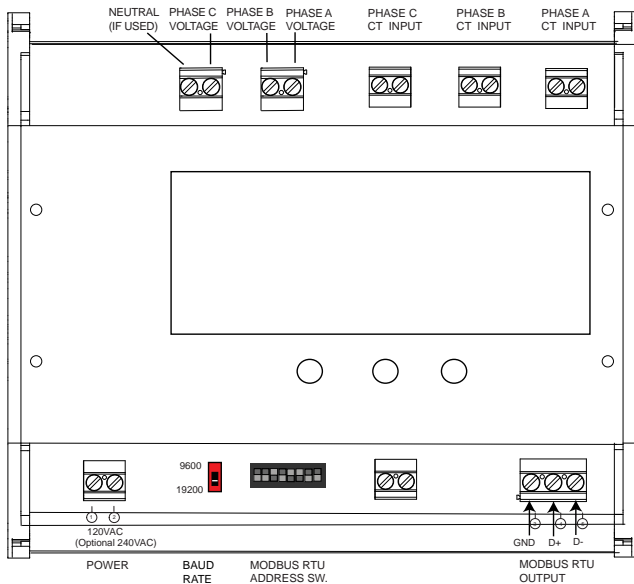

Power Sensing Specifications

Power Supply	24 VAC/DC, 120 VAC or 240 VAC
Output	<ul style="list-style-type: none"> Modbus RTU - 14 Data Points Pulsed Contact kWh
Display	4X20 LCD (Four lines, 20 characters each)
Voltage Ranges	100 to 600 VAC
Response Time	120 ms
Isolation Voltage	2200 VAC to meet UL standards
Frequency Range	50-100 Hz
Case	UL94 V0 Flammability Rated
Environmental	-4 to 122°F (-20 to 50°C) 0-95% RH, non-condensing
Listings	Designed to Meet UL 61010 Measurement Control and Laboratory Use (USA & Canada)

Power Sensing Data Point Table

	Phase A	Phase B	Phase C	Type
Current	*	*	*	RMS
Voltage	*	*	*	RMS
kW	*	*	*	Active
Power Factor	*	*	*	Instantaneous
Power Factor				Average
kWH				Total

Power Sensing Ordering Information

Sample Model Number: APN-600-RC 1-120-MOD
 AC Power transducer, 600 VAC maximum input, flexible current inputs (0-500 A range), 120 VAC powered, RS485 Modbus output with pulse contact for kWh.

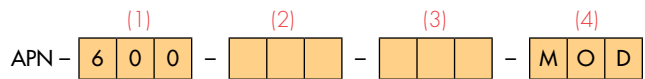

(1) Maximum Primary Voltage	600 600 VAC
(2) Current Input Type	RC1 Flexible coil sensors 0-500 A range RC2 Flexible coil sensors 0-2000 A range
(3) Rating Power Supply	24U 24 VAC/DC 120 120 VAC 240 240 VAC
(4) Output Type	MOD Modbus RTU (RS485), pulse contact for kWh