

## CE DECLARATION OF CONFORMITY

As Manufacturer:

### Monarch Instrument

Division of Monarch International Inc.  
15 Columbia Drive, Amherst NH 03031 USA  
declares under Monarch's sole responsibility that the product:

**SLS - Smart Laser Sensor**

to which this declaration relates is in conformity with the following directives and standards when installed and operated in accordance with the user manual:

**Directives:** EMC 89/336/EEC  
Low Voltage 73/23/EEC  
**Standards:** EMC: EN61326:1997  
Electrical Safety: IEC61010-1:2001  
Laser Safety: IEC60825-1:2001

References: Retlif Testing Laboratories, (Report No. R-4283)  
Technical Construction File SLS-0604 of June 2004

15<sup>th</sup> June 2004

Manufacturer (Amherst,NH)

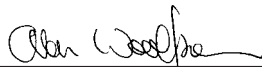

Alan Woolfson, VP Engineering (Authorized Signature)

Printed in the U.S.A.

Copyrighted by Monarch Instrument 2004, all rights reserved

**1071-4859-111**

## MONARCH INSTRUMENT

*Instruction Manual*



## SLS-115/230 Smart Laser Sensor



15 Columbia Drive  
Amherst, NH 03031-2334 USA  
Phone: (603) 883-3390  
Fax: (603) 886-3300  
E-mail: [support@monarchinstrument.com](mailto:support@monarchinstrument.com)  
Website: [www.monarchinstrument.com](http://www.monarchinstrument.com)

## SAFEGUARDS AND PRECAUTIONS



**WARNING** - This product emits a visible beam of laser light. Avoid exposure to the laser radiation. The use of optical viewing aids (binoculars, for example) may increase the ocular hazard.

**CAUTION** - The laser beam should not be intentionally aimed at people or animals.

**CAUTION** - Use of controls or adjustments or performance of procedures other than those specified herein may result in hazardous radiation exposure.

**WARNING** - Use only the “PR Universal” charger supplied with the product.



Read and follow all instructions in this manual carefully, and retain this manual for future reference.

Do not use this instrument in any manner inconsistent with these operating instructions or under any conditions that exceed the environmental specifications stated.

This instrument is not user serviceable. For technical assistance, contact the sales organization from which you purchased the product.

Examples:

1234.56<cr>

123456.<cr>

\_\_\_0.0<cr> ( \_ = space character)

## 10.0 CHARGING

Slide the Power switch (8) to the **Off/Charge** position and plug in the charger. The **Power LED** (4) will blink red while the unit is fast charging. The **Power LED** will blink amber when slow (trickle) charging. It will be solid amber when the batteries are fully charged.

**Note:** If the charger is plugged in when the Power switch is the on position, the batteries will be trickle charged during operation.

**CAUTION:** Use only the supplied PR-Universal charger with the sensor.

## 11.0 ACCESSORIES

T-5	Reflective Tape, 5 foot [1.5 m] roll, ½ inch [13 mm] wide
T-5WP	Waterproof Reflective Tape (honeycomb pattern), 5 foot [1.5 m] roll, 1 inch [25 mm] wide
SLS-CA-BNC	Cable assembly with BNC connector (SO)
SLS-CA-W	Cable assembly with tinned leads
SLS-CA-P	Cable assembly with 1/8 inch [3.5 mm] mono plug (SO)
SLS-CA-RS232	Cable assembly with DB9 connector for RS232
SLS Battery Pack	Replacement rechargeable Ni-Cd batteries
PR Universal	Recharger/Power Supply with assorted adapter plugs

To change the setting, move the Polarity switch (5) to the left (positive pulse) for a white target or to the right (negative pulse) for a black target. Turn the Sensitivity Adjust knob (7) to **Max**. Press and hold the Learn/Gain button (6) until the **Auto/Gain** LED (3) blinks.

## 8.0 AIMING THE LASER

The proper operation of the Laser Sensor is dependent upon the alignment to and reflectivity of the target. In order to aim the beam it is necessary to stand behind the sensor and view the target along the plane of the beam. **Do not stare directly into the laser beam or the reflected light.** For targets greater than 5 feet and up to 65 feet from the sensor, mount the laser on a tripod using the ¼ - 20 bushing on the bottom of the unit and attach T-5 reflective tape to the target.

To aid in locating the laser dot over a large distance, hold a piece of white cardboard or equivalent in front of the laser. Progressively move the white surface closer to the desired target. Then adjust the aim of the laser as necessary.

In areas of high ambient light (outdoors), performance can be enhanced at long distances by slipping a piece of black tube with a minimum inner diameter of 0.6 inches, over the nose piece to act as an extension nose piece. This tube should not deflect the beam in any way.

## 9.0 RS232

Baud rate = 9600, 8 bits, 1 stop bit, no parity.

When the unit is turned on, it will send out: “SLS<lf><cr>Vx.x<lf><cr>0.0<cr>”. Where <lf> is the linefeed character, <cr> is a carriage return character, and x.x is the firmware version number.

The unit will send out the current RPM as a right justified 7-digit ASCII number that will always include a decimal point followed by carriage return. The update rate is a function of the speed of the target and will not exceed twice per second.

## TABLE OF CONTENTS

1.0	SMART LASER SENSOR SPECIFICATIONS .....	1
2.0	OVERVIEW .....	4
3.0	INDICATORS AND SWITCHES .....	5
4.0	QUICK START GUIDE .....	6
5.0	CONNECTION DETAIL .....	7
6.0	OPERATION .....	9
	6.1 Auto Mode .....	9
	6.2 Manual Mode .....	10
7.0	ADVANCED FEATURE (TARGET POLARITY) .....	10
8.0	AIMING THE LASER .....	11
9.0	RS232 .....	11
10.0	CHARGING .....	12
11.0	OPTIONS / ACCESSORIES .....	12

Symbols on the unit and in this manual:



Warning  
Laser Beam

⎓ Direct current



Caution  
Read Manual

~ Alternating current

# 1.0 SMART LASER SENSOR SPECIFICATIONS

## Laser Specifications:

**Classification:** Class 3R (per IEC 60825-1 Ed 1.2 2001-8)  
Complies with FDA performance standards for laser products except for deviations pursuant to Laser Notice No. 50, dated July 26, 2001.

**Maximum Laser Output:** 3mW  
**Pulse Duration:** Continuous  
**Laser Wavelength:** 650 nm  
**Beam Divergence:** < 0.5 mrad  
**Beam Diameter:** 4 x 7 mm typical at 2 meters  
**Laser Diode Life:** 8,000 hours MTBF (1 year warranty)

Laser is on when this indicator is illuminated.

AVOID EXPOSURE  
LASER RADIATION IS  
EMITTED FROM THIS  
APERTURE.

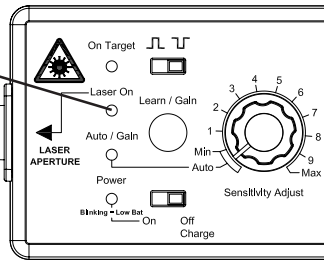

Figure 1 Laser Warnings

**Operating Range:** Up to 65 feet depending on target reflectivity:

- 1/2" reflective tape (T-5) @3600 RPM: up to 65 ft. (19.8 m) or up to 75° from target
- White/Black contrast @3600 RPM: up to 3 ft. (91 cm) or up to 45° from target
- Black mark on dental drill: up to 4 in. (10 cm) at over 260,000 RPM

In many applications, this is all that is needed. In cases where the target is marginal, the user may need to manually adjust the sensitivity after trying the Auto mode.

## 6.2 Manual Mode

Aim the laser at your target. Turn the Sensitivity Adjust knob (7) between **Min** and **Max** until the **On Target** LED (1) starts blinking or comes on solid. If you can't get a good setting, change the gain. Press and release the Learn/Gain button (6) to change the gain of the input amplifier. Each time the button is pressed, the gain is changed. The **Auto/Gain** LED (3) will blink to show what gain has been selected. If the button is held down, the gain will increase automatically after each LED 'blink' pattern. Refer to Table 2. The larger the gain, the weaker the signal being picked-up. Using a large gain for a strong signal is not recommended since the input will saturate.

Number of blinks	Gain
1 Strong Signal	X 1
2	X 2
3	X 4
4	X 5
5	X 8
6	X 10
7	X 16
8 Weak Signal - Move Closer	X 32

Table 2 Auto/Gain Blinks

## 7.0 ADVANCED FEATURE (TARGET POLARITY)

The input circuitry can be set to optimally work with two different target types: a reflective (white, shiny) target on a mostly non-reflective (black, dull) background or a non-reflective (black, dull) target on a mostly reflective (white, shiny) background. These will be referred to as a white target or a black target. When the unit is first turned on, the **On Target** LED (1) will indicate which target type the sensor is set up for. While the **Laser On** LED (2) is blinking, the **On Target** LED will be on for a white target or off for a black target. The unit will still work when set up for the "wrong" target type, but it won't have as great a range. When set for a white target, the unit triggers on the black to white transition. When set for a black target, the unit triggers on the white to black transition.

## 6.0 OPERATION

**Note:** Refer to Figure 3 for switch and button locations.

Turn the unit on by moving the Power switch (8) to the **On** position. The unit may be operated from the internal batteries and/or the charger/power supply. The internal batteries will be trickle charged when using the AC charger/power supply. To turn the unit off, slide the Power switch (8) to the **Off/Charge** position. If the charger is plugged in, the batteries will charge.

The sensor emits a laser beam, which is reflected back by a target (reflective tape/paint, keyway, contrasting colors, etc). This reflected light is sensed and amplified then compared to a threshold level (sensitivity) - the lower the threshold level, the more 'sensitive' the sensor is. Whenever the amplified signal is above the threshold, the output goes high (positive pulse) or low (negative pulse). The user can select either a positive or a negative output pulse using the Polarity switch (5).

The gain of the input amplifier and the sensitivity can be adjusted manually or automatically. This allows the unit to be used with many types of targets at various distances and contrasting color conditions. To select the Auto mode, turn the Sensitivity Adjust knob (7) fully counterclockwise, otherwise you are in the Manual mode. Reflective tape and high contrast color applications should be able to use the Auto mode.

### 6.1 Auto Mode

Make sure the Sensitivity Adjust knob (7) is fully counterclockwise and the **Auto/Gain** LED (3) is on. Aim the laser at your target. Press and hold the Learn/Gain button (6) until the **On Target** LED (1) blinks regularly or is on solid (depending on the RPM of the target). Release the Learn/Gain button. The **Auto/Gain** LED will blink to show what gain has been selected. Refer to Table 2.

**Max RPM:** 500,000 RPM

**Min. Trigger Duration:** 10  $\mu$ sec

**Indicators:** LEDs for On Target, Laser On, Auto/Gain, Power/Charge

**Modes:** Normal (manual) or Auto, and charging  
Normal mode – manual adjustment of sensitivity / gain  
Auto mode – auto learn, automatic gain control

**Sensitivity Adjust:** Single Turn knob on top panel in Normal mode

### Voltage Requirements:

**Operational:** Internal: rechargeable batteries  
External: +9 V  1VA

**Charging:** External: +9 V  3VA

**Batteries:** Internal 4 “AA” rechargeable NiCd 700mAh

**Run Time:** Over 6 hours continuous operation from fully charged batteries @ 70 °F (21 °C)

**Charge Time:** Typically less than 3 hours @ 70 °F (21 °C)

### PR Universal Charger:

**Input:** 100-240 V  , 50-60 Hz

**Output:** 9 V  , Dry location use only

Check charger label for power information.

### Pulse Output:

**SO:** Source Output - Square Wave 0 to 3.9V typical @ 15mA (PNP to 4.2V, 4.7K ohms to common) (TTL Compatible)

**OC:** Open Collector - Switches to common, External pull up resistor to user supplied power (max 24 V  ) required

## Pulse Output (continued):

Polarity: Positive or Negative pulse (switch selectable)

**RS232:** Transmit Out – ASCII value of RPM (Accuracy  $\pm$  0.002% of reading)

Settings: 9600 baud, 8 bits, 1 stop, No Parity

**Connector:** Circular DIN 5 Socket - Common, (Outputs) SO, OC, (Serial RS232) Transmit, Receive

**Dimensions:** 5.38" (13.67cm) L (including snout) x 2.53" (6.42cm) W x 2.25" (5.72cm) H (including knob and feet)

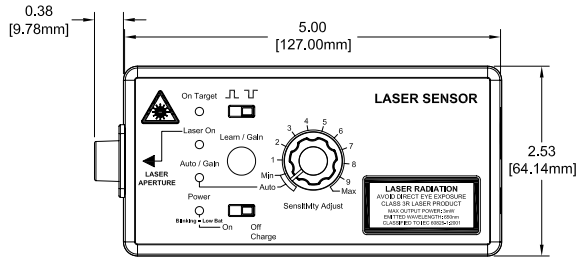
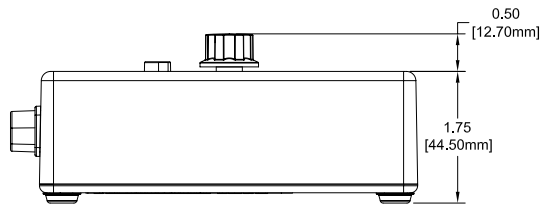

Figure 2 Dimensions in Inches [mm]



The output socket on the unit has the following connections:

Pin	Description	Wire Color (of cable)
1	RS232 Receive (input to sensor)	Red
2	Common	Orange [BNC -]
3	SO (PNP Output) TTL compatible output	Yellow [BNC +]
4	RS232 Transmit (output from sensor)	White
5	OC (NPN Output)	Black

Table 1 Output Connections

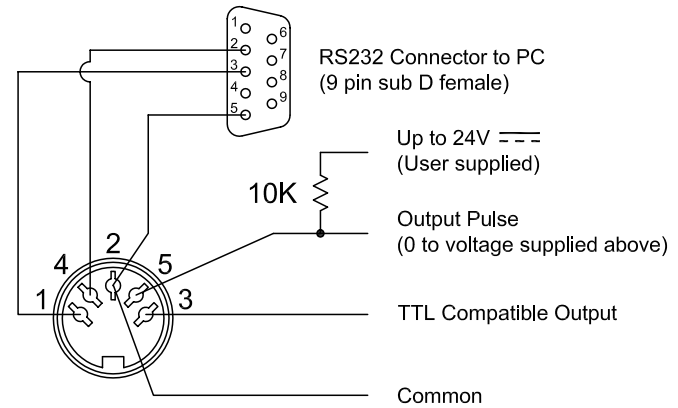

DIN Socket as viewed from the outside of the Sensor.

Figure 5 Pin Connections

- 4.5 If after completing step 4.4, the On Target LED (1) blinks erratically or not at all, rotate the Sensitivity Adjust knob (7) slowly from 1 to 9 until the LED blinks regularly or is on solid.
- 4.6 If after completing steps 4.1-4.5, the On Target LED (1) blinks erratically or not at all:
  - 4.6.1 Move the sensor closer to the target and ensure it is perpendicular to the target. Repeat steps 4.1-4.5.
  - 4.6.2 Increase the contrast/reflectivity of the target. Repeat steps 4.1-4.5.
- 4.7 Once the On Target signal is obtained, use the Polarity Switch (5) to select a compatible output pulse for your application.

## 5.0 CONNECTION DETAIL

The unit has an input power jack for DC power or recharging the batteries. Use only the PR Universal charger supplied.

The unit also has a five-pin DIN output socket for Pulse outputs and RS232. An 8-foot [2.5 m] cable with a DIN plug and BNC connector is supplied. The BNC plug is connected to the SO output. A variety of optional cables are available including: tinned wire termination, 1/8 inch [3.5 mm] mono plug, or DB9 for RS-232.

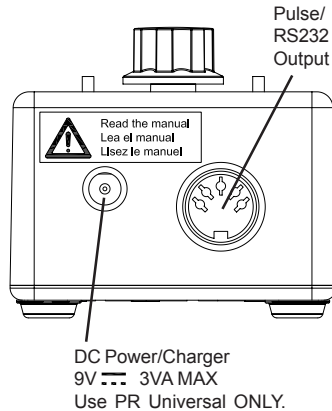

**Figure 4 Connection Details**

**Weight:** 10.6 oz (300.5 grams) excluding cable and charger

**Compliance:** CE 93/68/EEC EMC directive (EN 61326:2001)

IEC 61010-1 2001, IEC 60825-1 2001, CFR 1040.10 and 1040.11 except for deviations pursuant to Laser Notice No. 50, dated July 26, 2001

N.I.S.T. Calibration (RS232 output only)

**Mounting:** ¼-20 UNC Bushing included (Tripod Mount)

### Installation Environment:

**Installation Category II** per IEC 664

**Pollution Degree Level II** per IEC 61010-1

**Temperature:** 32 to 104 °F (0 to +40 °C) operating

14 to 158 °F (-10 to +70 °C) storage

**Humidity:** Maximum relative humidity of 80% for temperatures up to 88 °F (31 °C) decreasing linearly to 50% relative humidity at 104 °F (40 °C)

Specifications subject to change without notice.

## 2.0 OVERVIEW

The Smart Laser Sensor (SLS) is a self-contained unit intended to be used to make non-contact speed measurements from rotating targets at distances up to 65 feet (19.8 m) or to provide non-contact reference points to balancing equipment. Refer to Section 6.0 for an overview of operation. The unit will output one (TTL Compatible) pulse per revolution and has the ability to compute the RPM internally and output the ASCII values to any equipment capable of receiving an RS232 input. For best performance use reflective tape for the target.

### 3.0 INDICATORS AND SWITCHES

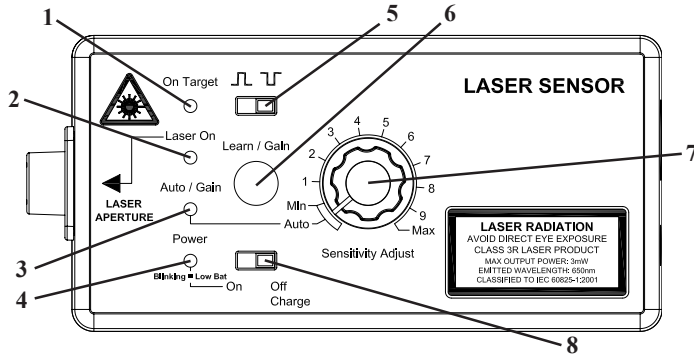

**Figure 3 Smart Laser Sensor**

1. **On Target LED** Lit whenever the sensor is receiving a reflected signal back from the target. As the frequency increases, it will be on solid unless the measured frequency is not stable. This is useful in setting up the unit.
2. **Laser On LED** Blinks when unit is first turned on. Remains lit when the laser beam is on.
3. **Auto/Gain LED** On solid whenever the unit is in the Auto mode. It also blinks from 1 to 8 times to indicate the current gain whenever the gain is changed.
4. **Power LED** (Dependent on the Power switch location)  
On position: GREEN when the batteries are charged.  
Blinks AMBER when the batteries are low.

- Charge position: Blinks RED when fast charging for very low batteries.  
Blinks AMBER when slow charging.  
Steady AMBER when the batteries are fully charged.

5. **Polarity switch** Selects either a positive or negative output pulse.
6. **Learn/Gain button**  
In Auto Mode: Press and hold until the On Target LED blinks regularly or is on solid.  
In Manual Mode: Press to change gain ranges.
7. **Sensitivity Adjust knob** Turn fully counterclockwise to select Auto mode or manually adjust sensitivity threshold.
8. **Power switch** Turns unit On or Off. When the unit is switched to Off/Charge and a charger is plugged into the unit, the batteries will charge.

### 4.0 QUICK START GUIDE

- 4.1 Slide Power switch (8) to “On”.
- 4.2 Rotate Sensitivity Adjust knob (7) fully counterclockwise to the “Auto” position.
- 4.3 Aim the laser dot perpendicular to the target - reflective tape, contrasting color or keyway.
- 4.4 If the On Target LED (1) is not on, push and hold the Red Learn/Gain button (6) until the On Target LED (1) blinks regularly. Note that at higher RPMs the LED will be on solid.