

Hydraulic comparison test pump Model CPP1200-X



WIKA data sheet CT 91.08

Applications

- Simple hydraulic test pressure generation on-site, in the laboratory or in the workshop
- For the testing, adjustment and calibration of all types of pressure measuring instruments
- Hydraulic pressure generation up to 1,200 bar

Special features

- Precisely adjustable dual-area spindle pump for filling, pressure generation and fine adjustment of pressure
- Freely rotating test connections (i.e. measuring instruments can be orientated)
- Proven technology of the model CPB3800 pressure balance
- Compact dimensions
- Low weight

Description

Application areas

Test pumps serve as pressure generators for the testing, adjustment and calibration of mechanical and electronic pressure measuring instruments through comparative measurements. These units can be used in the laboratory or workshop, or on site at the measuring point.

Easy operation

By connecting the test item and a sufficiently accurate reference pressure measuring instrument to the test pump, the same pressure will act on both measuring instruments. By comparison of the two measured values at any given pressure value, a check of the accuracy and/or adjustment of the pressure measuring instrument under test can be carried out.

Easy handling

The model CPP1200-X comparison test pump is a hydraulic comparison test pump for generating pressure up to 1,200 bar. It is technically identical to the instrument base of the model CPB3800 pressure balance. The integrated dual-area spindle



Comparison test pump CPP1200-X

pump with switching valves enables rapid filling of the test system and smooth pressure generation. At the same time, the precisely adjustable spindle pump also serves for pressure fine adjustment. A control schematic for pressure generation on the instrument base facilitates quick and easy operation.

The two test connections are equipped with G ½ female loose union connections. Corresponding thread adapters are available for the calibration of instruments with different connection threads.

Compact instrument design

The CPP1200-X is also particularly notable for its compact dimensions, which are not altered during operation, since the spindle runs within the pump body. With those dimensions, the exceptionally robust ABS plastic housing and the low weight associated with these, the CPP1200-X is also particularly suited for on-site applications.

Specifications		Model CPP1200-X
Pressure range	0 ... 1,200 bar	
Pressure transmission medium	Hydraulic fluid from mineral oil/clean water, free of calcium-carbonate ¹⁾	
Reservoir	170 cm ³	
Pressure connections		
Test item connection	2 x G ½ female thread, loose union connection	
Distance between test item connections	290 mm	
Piston of spindle pump		
Piston diameter, low-pressure piston	31.2 mm	
Piston diameter, high-pressure piston	12.7 mm	
Displacement	approx. 10 cm ³	
Material		
Wetted parts	Austenitic stainless steel, high tensile brass, nitrile rubber	
Permissible ambient conditions		
Operating temperature	0 ... 40 °C	
Instrument base		
Dimensions	401 x 397 x 155 mm (W x D x H), for details, see technical drawings	
Weight	13.5 kg	

1) Other pressure transmission media available on request.

Storage case (option)	
Material	Wood
Dimensions	664 x 614 x 380 mm (W x D x H)
Weight	8.5 kg

CE conformity	
Pressure equipment directive	97/23/EC (PS > 1,000 bar; Module A, pressure accessory)

Approvals and certificates, see website

Dimensions in mm

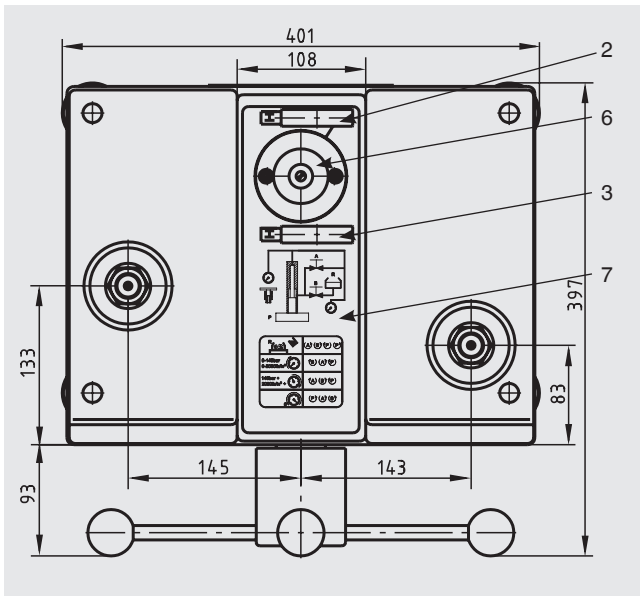
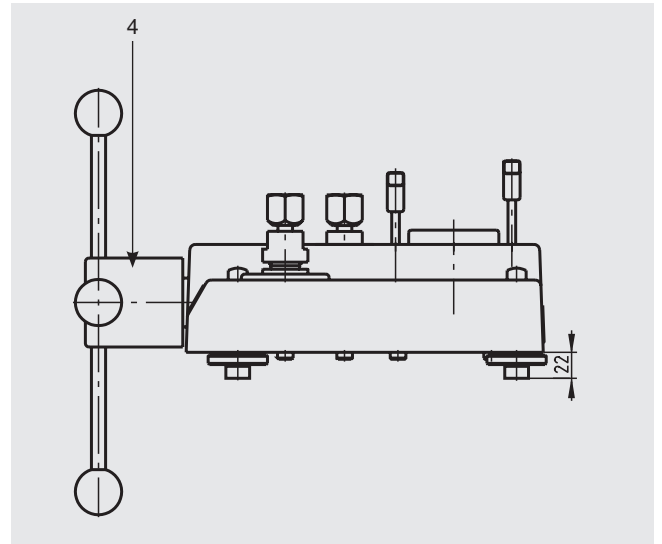
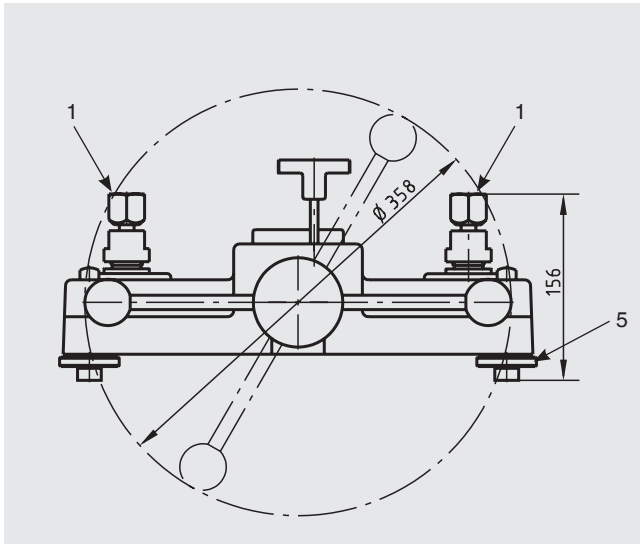

- (1) Test item connections
- (2) High-pressure shut-off valve
- (3) Low-pressure shut-off valve
- (4) Dual-area spindle pump with star handle
- (5) Rotatable feet
- (6) Reservoir with sealing plug
- (7) Pressure generation control schematic

Test item connection

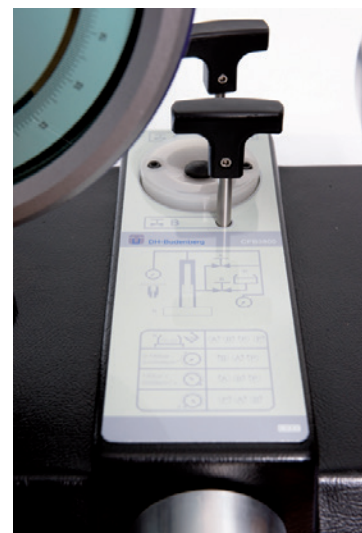
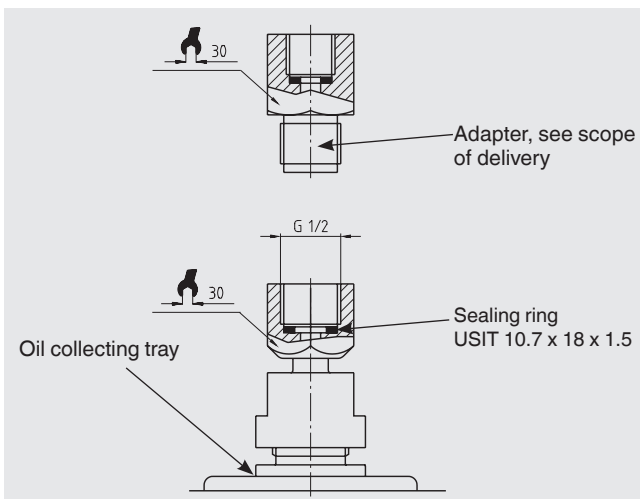

Control schematic on the CPP1200-X instrument base

Accessories

Designation/Variant	Order no.
Storage case for CPP1200-X instrument base	14031237
"BSP" adapter set for G ½ B male test item connector to G ⅛, G ¼, G ⅜ and G ½ female	14031238
"NPT" adapter set for G ½ B male test item connector to ⅛ NPT, ¼ NPT, ⅜ NPT and ½ NPT female	14031239
"Metric" adapter set for G ½ B male test item connector to M12 x 1.5 and M20 x 1.5 female	14031242
Adapter for test item connection, G ½ B male on M16 x 1.5 male with sealing cone, material: stainless steel hardened	11580454
Test item connection piece, G ¾ female to G ½ female, loose union connection	14031251
90° angle connection, for test items with back mounting connection	1564838
Sealing and maintenance set for instrument base, standard version	14031255
Hydraulic fluid based on VG22 mineral oil in plastic bottle, content 0.5 litre	2099954
Tool set consisting of open-ended spanner, BSP adapter, replacement seals, pointer remover and pointer punch	14031263

Recommended reference pressure measuring instruments:

Precision digital pressure gauge model CPG1000

Measuring ranges: up to 700 bar

Accuracy: 0.05 % of span

For further specifications see data sheet CT 10.01



Hand-held pressure indicator model CPH6300

Measuring ranges: up to 1,000 bar

Accuracy: 0.2 % of span

For further specifications see data sheet CT 12.01



Precision hand-held pressure indicator model CPH6400

Measuring ranges: up to 6,000 bar

Accuracy: up to 0.025 % of span

For further specifications see data sheet CT 14.01



ProcessCalibrator model CPH6000

Measuring ranges: up to 6,000 bar

Accuracy: up to 0.025 % of span

For further specifications see data sheet CT 15.01



Scope of delivery

- Instrument base
- Dual-area spindle pump for filling, pressure generation and pressure fine adjustment
- 2 test item connections with G ½ female thread, loose union connection
- Adapter set for test item selectable from 3 different sets:
 - Set of adapters "BSP" G ½ male on G ½, G ¼, G ⅜ and G ½ female
 - Set of adapters "NPT" G ½ male on ½ NPT, ¼ NPT, ⅜ NPT and ½ NPT female
 - Set of adapters "metric" G ½ male on M12 x 1.5 and M20 x 1.5 female
- VG22 mineral oil (0.5 litre)
- Tool and maintenance set
- Operating instructions in German and English language

Options

- Versions for medium water or Skydrol
- Storage case for instrument base



Calibration assembly CPP1200-X with test gauge as reference instrument and test item

Ordering information

Model / Package / Medium / Standard set of adapters / Additional adapter set / Angle connection / Storage case / Accessories / Additional order information

© 2013 WIKA Alexander Wiegand SE & Co. KG, all rights reserved.
The specifications given in this document represent the state of engineering at the time of publishing.
We reserve the right to make modifications to the specifications and materials.

WIKA data sheet CT 91.08 · 06/2014

Page 5 of 5