

Pressure Sensor with Ceramic Sensing Element



measuring
•
monitoring
•
analyzing

SEN-9601



- Measuring Range:
-14.5... 0 PSIG to 0... 6000 PSIG
- Max. Media Temperature: 185 °F
- Linearity: $\pm 0.5\%$
- Output: Voltage or Current
- Connection: 1/4" NPT, 1/2" NPT,
G 1/4, or G 1/2
- OEM Targeted Product



Contact:
Industrial Process Measurement, Inc.
3910 Park Avenue, Unit 7
Edison, NJ 08820
732-632-6400
support@instrumentation2000.com
<http://www.instrumentation2000.com>



Description

The KOBOLD SEN-9601 model is an electronic pressure transmitter with a ceramic sensor commonly used for air, industrial & technical gases, water, and oil. It is designed to be installed in gas distribution plants, on bottles, on refrigerators, on compressors, on vacuum pumps, in hydraulics, and in high pressure water plants. It is ideally suited to be used for general industrial applications, gas stocking, machine production, light or heavy pneumatics industry, the refrigeration industry, or in welding & vacuum applications.

Technical Data

Ranges

- Standard: -30...0" HG to 0...6000 PSIG
- Compound: -30" Hg/15 PSIG to -30" HG/150 PSIG
- Accuracy: $\leq \pm 1.0\%$ of the range*
- Linearity (BFSL): $\leq \pm 0.5\%$ of the range, according to EN 61298-2
- Repeatability: $\leq 0.1\%$ of the range, according to EN 61298-2

Output signal

- Deviation of zero: $\leq \pm 0.5\%$ of span, typical; $\leq \pm 0.8\%$ of span, max.
- Thermal drift: Between 32°F and 176°F, 1% of span; 2.5% of span, max.
- Long term drift: $\leq 0.2\%$ of span, according to EN 61298-2

Process fluid, ambient, and stocking

- temperature: -10...185°F
- Output signals: 4...20 mA, 0...5 V_{DC}, 0...10 V_{DC}, 1...5 V_{DC}, 0.5...4.5 ratiometric V_{DC}

- Response time: <4 ms
- Emission and immunity: According to EN 61326, (group 1 - class B; industrial applications)

- Process connection: 316L, hole \varnothing 2.5 mm
- Sensor: Ceramic in Al₂O₃
- Case: 316L, vented up to 200 PSIG
- Gasket (Sensor): FKM
- Electric connection: DIN 43650 A
- Protection degree: IP 65 according to IEC 529 / EN 60529**
- Weight: 0.27 lb

* Including linearity, hysteresis, repeatability, and output signal deviation of zero at the reference conditions described in standard EN 61298-1

** With properly assembled electric connection.

Ranges	Overpressure
-30...150 inHg/PSIG	290 PSIG
-30...100 inHg/PSIG	174 PSIG
-30...60 inHg/PSIG	116 PSIG
-30...30 inHg/PSIG	72.5 PSIG
-30...15 inHg/PSIG	72.5 PSIG
-30...0 inHg	72.5 PSIG
0...15 PSIG	72.5 PSIG
0...30 PSIG	72.5 PSIG
0...60 PSIG	116 PSIG
0...100 PSIG	174 PSIG
0...150 PSIG	290 PSIG
0...200 PSIG	464 PSIG
0...300 PSIG	580 PSIG
0...500 PSIG	1160 PSIG
0...600 PSIG	1160 PSIG
0...1000 PSIG	1740 PSIG
0...1500 PSIG	2900 PSIG
0...2000 PSIG	4640 PSIG
0...3000 PSIG	7250 PSIG
0...4000 PSIG	7250 PSIG
0...5000 PSIG	8700 PSIG
0...6000 PSIG	8700 PSIG

Other ranges available upon request.

Dimensions (in mm)

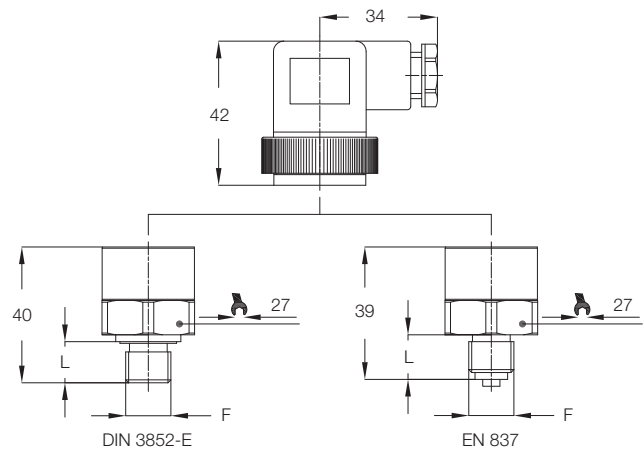

F ¹⁾	L (mm)
A - G ½, male EN 837	20
B - G ¼, male EN 837	13
E - G ¼, male DIN 3852-E	13
F - ½ - 14 NPT	20
G - ¼ - 18 NPT	13

¹⁾ Torque 20...30 Nm

Wiring Diagram

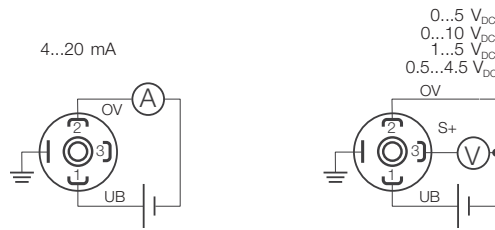

Order Details: (Example: **SEN-9601 0 P085 G 0**)

Model	Output	Measuring Range	Mechanical Connection	Options
SEN-9601..	..0.. = 4-20 mA, 2-wire (standard)	..H375*.. = -30...150 inHg/PSIG ..H365*.. = -30...100 inHg/PSIG ..H360*.. = -30...60 inHg/PSIG ..H345*.. = -30...30 inHg/PSIG ..H325*.. = -30...15 inHg/PSIG	..A*.. = G 1/2, male	..0 = without ..C = Hirschmann electrical connector with 1/2" NPT conduit
	..1*.. = 0...5 V _{DC} (8...30 V _{DC})	..H315.. = -30...0 inHg ..P025.. = 0...15 PSIG ..P045.. = 0...30 PSIG	..B*.. = G 1/4, male	
	..2*.. = 0...10 V _{DC} (14...30 V _{DC})	..P060.. = 0...60 PSIG ..P065.. = 0...100 PSIG	..E*.. = G 1/4 DIN 3852-E, male	
	..3*.. = 0.5...4.5 V _{DC} ratiometric (5 V _{DC} ±10%)	..P075*.. = 0...150 PSIG ..P085.. = 0...200 PSIG ..P090.. = 0...300 PSIG	..G.. = 1/4" NPT, male (standard)	
	..4*.. = 1...5 V _{DC} (8...30 V _{DC})	..P100.. = 0...500 PSIG ..P105*.. = 0...600 PSIG ..P115.. = 0...1000 PSIG ..P126*.. = 0...1500 PSIG ..P130.. = 0...2000 PSIG ..P140.. = 0...3000 PSIG ..P146.. = 0...4000 PSIG ..P150.. = 0...5000 PSIG ..P160*.. = 0...6000 PSIG	..F*.. = 1/2" NPT, male	

* Minimum order quantity = 20 pieces per item (identical model code)

Output Signal Code	4...20 mA 0	0...5 V _{DC} 1	0...10 V _{DC} 2	0.5...4.5 V _{DC} ratiometric 3	1...5 V _{DC} 4
No. of wires	2	3	3	3	3
Load max. (Ω)	$R_L \leq (V_{in}-8)/0.02$	$R_L \geq 5 \text{ K}\Omega$	$R_L \geq 10 \text{ K}\Omega$	$R_L \geq 4.5 \text{ K}\Omega$	$R_L \geq 5 \text{ K}\Omega$
Supply: +Vin (V _{DC})	8...30	8...30	14...30	5 ±10%	8...30
Absorbed current (mA)	<25	<10	<10	<10	<10

All output signals are provided protected against short circuit and polarity inversion. Insulation tension 500 V_{DC}.