

Paddle Type Flow Switch for Liquids



measuring
•
monitoring
•
analyzing

PSR / PS



- Switch Point Adjustable
- Easy to Install
- Brass or SS Construction
- Low Cost
- Maximum Pressure, Brass: 1450 PSIG
- Maximum Pressure, SS: 3625 PSIG



Contact:
Industrial Process Measurement, Inc.
3910 Park Ave, Unit #7
Edison, NJ 08820 USA
(732) 632-6400
support@instrumentation2000.com
<https://www.instrumentation2000.com/>

KOBOLD Instruments, Inc.



Paddle Type Flow Switch Models PSR/PS

Description

The KOBOLD PSR and PS are simple, economical and reliable monitors for flow switching applications. They operate as follows: The flowing media presses against the paddle fitted to one end of a balance arm which is in direct contact with a pre-stressed leaf spring. At the other end of the arm is a permanent magnet. This magnet actuates a reed contact in a bistable fashion located within a movable housing located outside of the media. The reed contact switches on or off depending on the position of the magnet and the switch housing. The switch status may then be used to control flow as the contacts can be set to normally open or normally closed. The PSR is made of brass or stainless steel with 1/4" NPT to 1-1/2" NPT fittings. The PS is made of brass or stainless steel with a 1/2" NPT fitting and is designed for installation in 2" to 8" pipes. Common applications include: cooling and lubricant circuits, dry running protection for pumps, prevention of low water levels, and monitoring for pipe breakage.



Model PS



Model PSR

Specifications

Switching Tolerance: ± 15%

Media Temperature
Brass/NBR Seal: -4...158 °F
SS/FPM Seal: 14...230 °F

Ambient Temperature
Brass/NBR Seal: -4...158 °F
SS/FPM Seal: -4...230 °F

Max. Pressure
Brass: 1/4"...1" = 1450 PSIG
 1-1/4"...1-1/2" = 360 PSIG
SS: 1/4"...1" = 3600 PSIG
 1-1/4"...1-1/2" = 580 PSIG

Ingress Protection: IP 65

Mounting Orientation: Horizontal Flow Preferred

Max Flow Rate: 5x Switching Range, Increasing

Maximum Contact Ratings (cCSAus):
SPST Contact: 2A, 20 V_{AC}, 0.18 A, 230 V_{AC}, max. 40 W
SPDT Contact: 0.13 A, 150 VAC, 0.5 A, 40 VAC, max. 20 W

Cable: PVC Jacketed
Cable Length: Standard: 5 Ft. (1.5m)
 Optional (SPST only): 10, 15 or 21 Ft.

Materials

	PSR/PS-51..	PSR/PS-52..
Case	MS58 Brass	304 SS
Paddle	304 Stainless Steel	
Leaf Spring	301 Stainless Steel	
Balance Arm	301 Stainless Steel	
Sleeve	MS58 Brass	304 SS
Magnet	Oxide Ceramics	
Seal	NBR	FKM
Contact Tube	Polyamide, Glass Reinforced	

*U.S. Patent Number: 4,827,092

Order Details: PSR w/Standard Switching Ranges (Example: PSR-5105)

Connection (NPT)	Approximate Switching Range*		Model / Material		Options
	Increasing GPM (Water)	Decreasing GPM (Water)	Brass	Stainless Steel	
1/4"	0.6...1.2	0.4...1.2	PSR-5105	PSR-5205	..U = SPDT Switch, 5 Ft. Cable ..EC10 = SPST w/10 Ft. Cable ..EC15 = SPST w/15 Ft. Cable ..EC21 = SPST w/21 Ft. Cable
3/8"	0.7...1.5	0.6...1.4	PSR-5110	PSR-5210	
1/2"	0.7...1.6	0.5...1.6	PSR-5115	PSR-5215	
3/4"	2.0...3.5	1.6...3.4	PSR-5120	PSR-5220	
1"	2.0...4.8	1.9...4.5	PSR-5125	PSR-5225	
1-1/4"	5.8...10.2	5.6...9.5	PSR-5132	PSR-5232	
1-1/2"	9.2...17.0	9.0...16.5	PSR-5140	PSR-5240	

*Listed values are valid only for horizontal installations



Order Details: PSR with Special Switching Ranges (Example: **PSR-5105 2**)

Connection (NPT)	Approximate Switching Range*		Model / Material		Option
	Increasing GPM (Water)	Decreasing GPM (Water)	Brass	Stainless Steel	
1/4"	1.3...1.7	0.9...1.6	PSR-5105 2	PSR-5205 2	..U = SPDT Switch, 5 Ft. Cable ..EC10 = SPST w/10 Ft. Cable ..EC15 = SPST w/15 Ft. Cable ..EC21 = SPST w/21 Ft. Cable
	1.5...2.0	1.2...2.0	PSR-5105 1	PSR-5205 1	
3/8"	1.5...1.8	1.2...1.8	PSR-5110 2	PSR-5210 2	
	1.8...2.2	1.5...2.2	PSR-5110 1	PSR-5210 1	
1/2"	2.2...2.8	1.9...2.7	PSR-5115 2	PSR-5215 2	
	2.5...3.2	2.2...3.1	PSR-5115 1	PSR-5215 1	
3/4"	4.7...6.5	4.0...6.1	PSR-5120 5	PSR-5220 5	
	5.4...7.9	4.3...7.4	PSR-5120 4	PSR-5220 4	
	9.2...12.7	8.1...12.3	PSR-5120 1	PSR-5220 1	
1"	4.7...7.0	3.4...6.5	PSR-5125 7	PSR-5225 7	
	6.9...9.5	5.7...9.0	PSR-5125 5	PSR-5225 5	
	7.9...11.3	6.6...10.8	PSR-5125 4	PSR-5225 4	
	12.6...17.7	11.6...17.1	PSR-5125 1	PSR-5225 1	

*Listed values are valid only for horizontal installations

Order Details: PS (Example: **PS-5149**)

Pipe Size	Approximate Switching Range*		Connection	Model / Material		Option
	Increasing GPM (Water)	Decreasing GPM (Water)		Brass	Stainless Steel	
2"	18...24	16...22	1/2" NPT	PS-5149	PS-5249	..U = SPDT Switch, 5 Ft. Cable ..EC10 = SPST w/10 Ft. Cable ..EC15 = SPST w/15 Ft. Cable ..EC21 = SPST w/21 Ft. Cable
3"	48...66	45...62				
4"	84...106	79...101				
6"	185...242	176...237				
2"	13...16	11...15		PS-5152	PS-5252	
3"	41...48	38...44				
4"	57...70	53...66				
6"	147...159	137...156				
4"	24...30	19...27		PS-5114	PS-5214	
6"	53...75	44...62				
8"	101...141	88...123				

*Listed values are valid only for horizontal installations



Dimensions

Model PS-..49

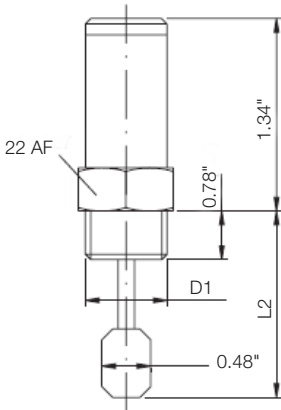

Models PS-..52 and PS-..14

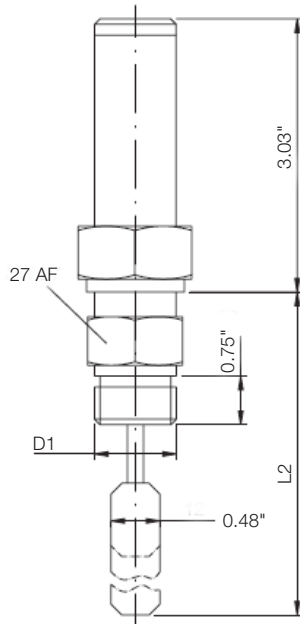

Model PSR

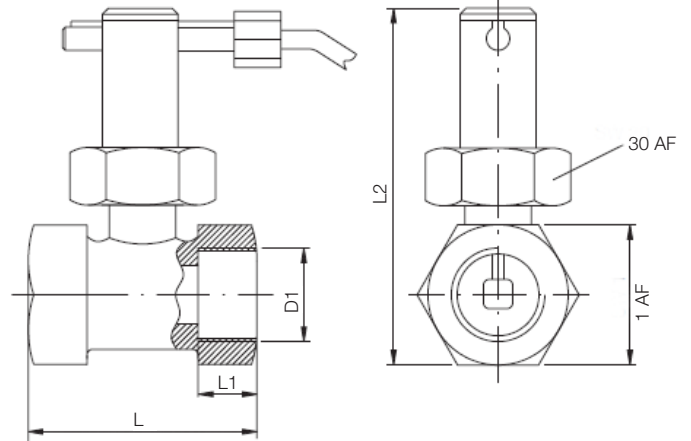

Model	D1	L2
PS-..49	1/2" NPT	2.32"
PS-..52	1/2" NPT	2.83"
PS-..14	1/2" NPT	5.12"

Model	D1	L	L1	L2	1 AF
PSR-..05	1/4" NPT	1.97"	0.39"	3.70"	1.06"
PSR-..10	3/8" NPT	1.97"	0.39"	3.70"	1.06"
PSR-..15	1/2" NPT	1.97"	0.39"	3.70"	1.06"
PSR-..20	3/4" NPT	2.05"	0.59"	3.85"	1.25"
PSR-..25	1" NPT	2.20"	0.59"	4.08"	1.54"
PSR-..32	1-1/4" NPT	2.60"	-	4.49"	1.97"
PSR-..40	1-1/2" NPT	2.60"	-	4.79"	2.36"

Switch Point Setting

To adjust the switch set-point, slightly loosen the two screws that secure the locking washer at the top of the casing and move the contact unit. Blue/white & red arrows located on the contact unit serve as an adjustment aid. The front edge of the locking washer serves as an adjustment mark.

N/O Contact

The switching volume may then be adjusted at the red arrow. The minimum switching values specified in the table are set by moving the contact unit in the flow direction. The maximum switching values noted in the table are set by moving the contact unit against the direction of flow. Evenly tighten the two screws that secure the locking washer after the desired settings have been made.

N/C Contact

The switching volume may then be adjusted at the blue/white arrow. The minimum switching values specified in the table are set by moving the contact unit in the flow direction. The maximum switching values noted in the table are set by moving the contact unit against the direction of flow. Evenly tighten the two screws that secure the locking washer after the desired settings have been made.

