

Units for regulation and
monitoring of pressure

type KRT

Units for regulation and monitoring of pressure, type KRT

Pressure controls type KRT

0 5 10 15 20 25 30 bar										Range p_e bar	Type	Further information										
										-1 -0	RT 121	See contents page 3										
										0 -0.3	RT 113											
										0.1 -1.1	RT 112											
										0.2 -3	RT 110											
										<i>Standard pressure controls</i>										-0.8 -5	RT 1, 1A	
										0.2 -6	RT 200											
										1 -10	RT 116											
4 -17	RT 5, 5A																					
10 -30	RT 117																					
										0.1 -1.1	RT 112 W											
										0 -2.5	RT 33B, RT 35 W											
										1 -10	RT 30 AW/AB/AS											
										1 -10	RT 116W											
										2 -10	RT 31 W/B/S											
										5 -25	RT 19 W/B/S											
										5 -25	RT 32 W/B/S											
																				-0.8 -5	RT 1AL	
0.2 -3	RT 110L																					
0.2 -6	RT 200L																					
4 -17	RT 5AL																					
										10 -30	RT 117L											
										<i>Differential pressure controls</i>										-1 -6	RT 266AL	
																				-1 -6	RT 263AL	
																				-1 -9	RT 262AL/A	
																				-1 -18	RT 260AL/A	
-1 -36	RT 260A																					
										-1 -36	RT 265A											

Pressure controls, type KRT

Contents

	Page		Page
Survey of types, pressure ranges	2	Function description	9
Introduction	3	Function description fail-safe, J	10
Technical data and code nos., all types	4-5	Pressure control for liquid level control	10
Approvals	5	Pressure controls with adjustable neutral zone	11-12
Technical data and material in contact with medium	6	Differential pressure controls	13-14
Dimensions and weight	7		
Installation	8		

Introduction

Type RT pressure controls incorporate a pressure controlled, single-pole changeover switch where the contact position depends on the pressure in the connection port and the set value. The RT series consists of pressure controls, differential pressure controls and pressure controls for neutral zone regulation. These units are for general use within the industrial and marine sectors. The RT series also covers safety pressure controls for steam boiler plant.

For installations in which operation is particularly critical from safety and economic points of view, the use of fail-safe pressure controls is recommended. The use of gold-plated contacts is also recommended in such installations, provided operation involves only a few switching cycles or low signal currents and voltages.

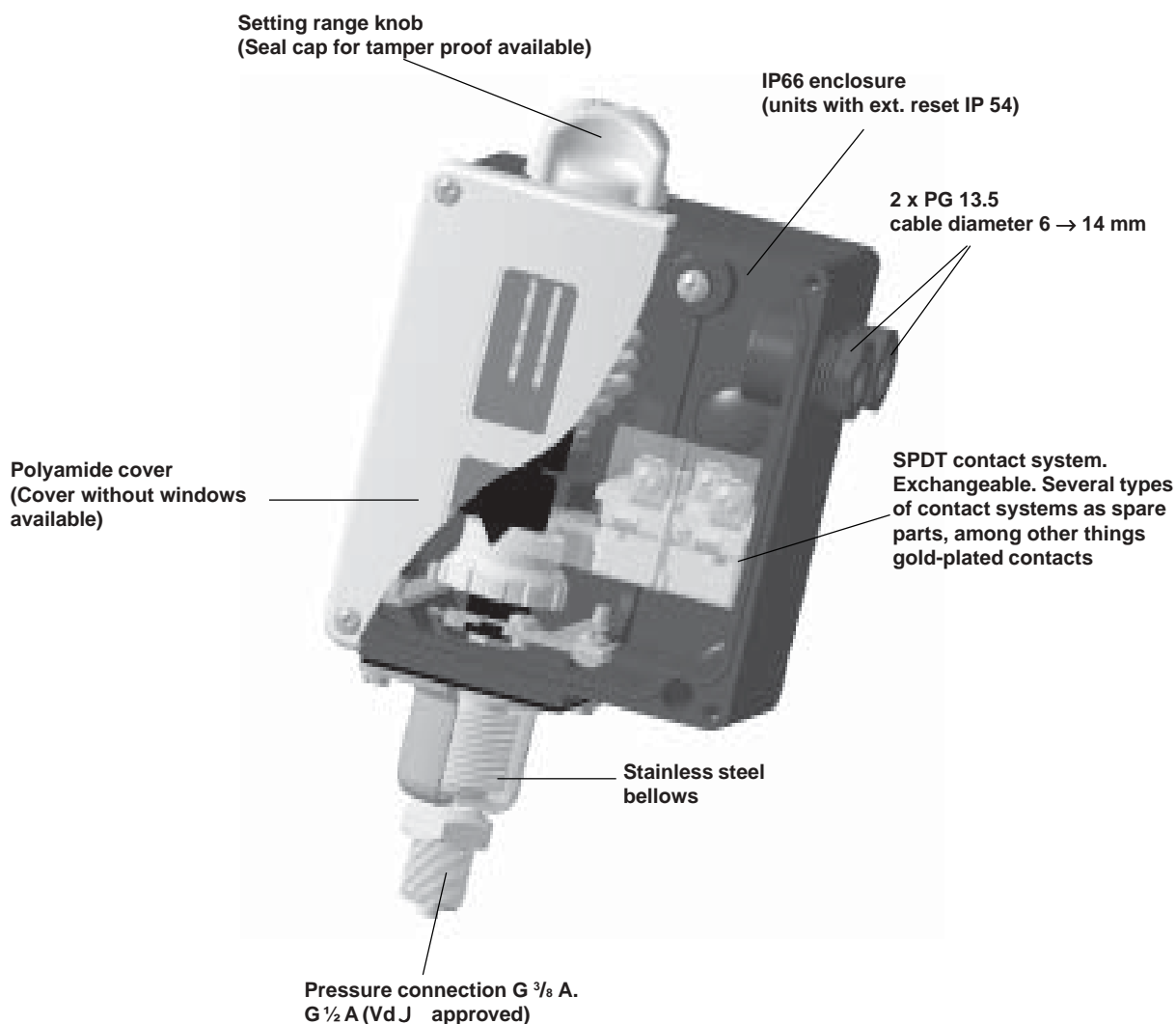

Pressure controls, type KRT

Technical data and code nos.

When ordering, please state type and code number.

The type designation for the letters below means:
A: Unit suitable for the medium ammonia
L: Unit with neutral zone

Pressure controls Preferred versions

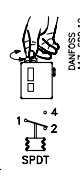
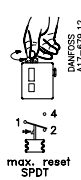
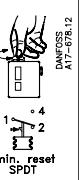
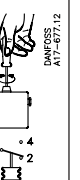
Regulation range (p_e = effective pressure) bar	Adjustable/ fixed mechanical differential bar	Max. operating pressure PB bar	Max. test pressure p' bar	Pressure connection ISO 228/1 bar	Code no.				Type
					 DANFOSS A17-525,12 SPDT	 DANFOSS A17-525,12 max. reset SPDT	 DANFOSS A17-525,12 min. reset SPDT	 DANFOSS A17-527,12 SPDT	
-1 -0	0.09 -0.4	7	8	G 3/8 A	017-5215				RT 121
0 -0.3	0.01 -0.05	0.4	0.5	G 3/8 A	017-5196				RT 113
0 -0.3	0.01 -0.05	0.4	0.5	G 3/8 A	017-5073³⁾				RT 113
0.1 -1.1	0.07 -0.16	7	8	G 3/8 A	017-5191			017-5193	RT 112
0.1 -1.1	0.07	7	8	G 3/8 A		017-5192			RT 112
0.2 -3	0.08 -0.25	7	8	G 3/8 A	017-5291			017-5292	RT 110
0.2 -3	0.08	7	8	G 3/8 A			017-5110		RT 110
-0.8 -5	0.5 -1.6	22	25	7/16-20 UNF	017-5245				RT 1
-0.8 -5	0.5	22	25	7/16-20 UNF			017-5246		RT 1
-0.8 -5	0.5 -1.6	22	25	G 3/8 A ¹⁾	017-5001				RT 1A
-0.8 -5	0.5	22	25	G 3/8 A ¹⁾			017-5002		RT 1A
-0.8 -5	1.3 -2.4	22	25	G 3/8 A ¹⁾	017-5007				RT 1A
0.2 -6	0.25 -1.2	22	25	G 3/8 A	017-5237			017-5240	RT 200
0.2 -6	0.25	22	25	G 3/8 A		017-5238	017-5239		RT 200
1 -10	0.3 -1.3	22	25	G 3/8 A	017-5203			017-5200	RT 116
1 -10	0.3	22	25	G 3/8 A		017-5204	017-5199		RT 116
4 -17	1.2 -4	22	28	G 3/8 A	017-5255			017-5253	RT 5
4 -17	1.2	22	28	G 3/8 A		017-5094²⁾			RT 5
4 -17	1.2 -4	22	28	G 3/8 A ¹⁾	017-5046²⁾				RT 5A
4 -17	1.2	22	28	G 3/8 A ¹⁾		017-5047²⁾			RT 5A
10 -30	1 -4	42	47	G 3/8 A	017-5295			017-5296	RT 117

¹⁾ Supplied with $\varnothing 6/\varnothing 10$ mm weld nipple. ²⁾ With seal cap. ³⁾ DNV approved with EPDM diaphragm.



RT 113
for manual setting;
cover with windows



RT 116
for tamper proof;
cap and blank cover



RT 262 A
Differential pressure
control

Pressure controls with adjustable neutral zone

Regulation range (p_e) bar	Mechanical differential bar	Adjustable neutral zone bar	Max. operating pressure PB bar	Max. test pressure p' bar	Pressure connection	Code no.	Type
-0.8 -5	0.2	0.2 -0.9	22	25	G 3/8 A ¹⁾	017L0033	RT 1AL
0.2 -3	0.08	0.08 -0.2	7	8	G 3/8 A	017L0015	RT 110L
0.2 -6	0.25	0.25 -0.7	22	25	G 3/8 A	017L0032	RT 200L
4 -17	0.35	0.35 -1.4	22	25	G 3/8 A ¹⁾	017L0040	RT 5 AL
10 -30	1	1 -3.0	42	47	G 3/8 A	017L0042	RT 117L

¹⁾ Supplied with $\varnothing 6/\varnothing 10$ mm weld nipple.

Differential pressure controls

Regulation range Δp bar	Mechanical differential bar	Adjustable neutral zone bar	Operation range bar	Max. operating pressure PB bar	Max. test pressure p' bar	Pressure connection ISO 228/1	Code no.	Type
0 -0.9	0.05	0.05 -0.23	-1 -6	7	8	G 3/8 A ¹⁾	017D0081	RT 266AL
0.1 -1.0	0.05	0.05 -0.23	-1 -6	7	8	G 3/8 A ¹⁾	017D0045	RT 263AL
0.1 -1.5	0.1	0.1 -0.33	-1 -9	11	13	G 3/8 A ¹⁾	017D0043	RT 262AL
0.1 -1.5	0.1		-1 -9	11	13	G 3/8 A ¹⁾	017D0025	RT 262A
0 -0.3	0.035		-1 -10	11	13	G 3/8 A ¹⁾	017D0027²⁾	RT 262A
0.5 -4	0.3	0.3 -0.9	-1 -18	22	25	G 3/8 A ¹⁾	017D0048	RT 260AL
0.5 -4	0.3		-1 -18	22	25	G 3/8 A ¹⁾	017D0021	RT 260A
0.5 -6	0.5		-1 -36	42	47	G 3/8 A ¹⁾	017D0023	RT 260A
1.5 -11	0.5		-1 -31	42	47	G 3/8 A	017D0024	RT 260A
1 -6	0.5		-1 -36	42	47	G 3/8 A ¹⁾	017D0072³⁾	RT 265A

Pressure controls, type KRT

Technical data and code nos.

The designation letters mean:
 A: Units suitable for the medium ammonia.
 W: Units for control purposes.

B: Safety units with external reset
 S: Safety units with internal reset

Pressure controls for steam plant, approved by Vd J

Preferred versions

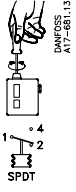
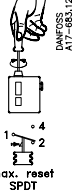
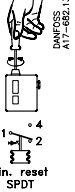
Regulation range (p _e -effective pressure)	Adjustable/ fixed mechanical differential	Max. operating pressure	Max. test pressure	Pressure connection	Code no.			Type
								
bar	bar	PB	p'					

For rising pressure, approved acc. to PED

0.1 –1.1	0.07	7	8	G ½A	017-5282		RT 112W
0 –2.5	0.1	7	8	G ½A	017-5280		RT 35W
1 –10	0.8	22	25	G ½A	017-5187		RT 30AW
1 –10	0.4	22	25	G ½A		017-5188	RT 30AB
1 –10	0.4	22	25	G ½A		017-5189	RT 30AS
5 –25	1.2	42	47	G ½A	017-5181		RT 19W
5 –25	1	42	47	G ½A		017-5182	RT 19B
5 –25	1	42	47	G ½A		017-5183	RT 19S

For falling pressure

0 –2.5	0.1	7	8	G ½A		017-5262	RT 33B
2 –10	0.3 –1	22	25	G ½A	017-5267		RT 31W
2 –10	0.3	22	25	G ½A		017-5268	RT 31B
2 –10	0.3	22	25	G ½A		017-5269	RT 31S
5 –25	0.8 –3	42	47	G ½A	017-5247		RT 32W
5 –25	0.4	42	47	G ½A		017-5248	RT 32B

Pressure control for low pressure steam plant (pressure monitoring)

0.1 –1.1	0.07 –0.16	7	7	G ½A	017-5184		RT 112
----------	------------	---	---	------	-----------------	--	--------

Approvals

RT 1	RT1A RT 5A RT 121	RT 1AL	RT 5	RT 30AW RT 30AB RT 30AS RT 19W RT 19B RT 19S	RT 31W RT 31B RT 31S RT 32W RT 32B RT 32S	RT 33B RT 35W RT112W RT116W	RT 110	RT 112	RT 113	RT 116 RT 117 RT 200	RT 117L RT 200L	RT 260A RT 262A RT 265A RT 260AL RT 262AL RT 263AL RT 266AL	Approvals
x	x	x	x	x	x	x	x	x	x	x	x	x	DEMKO, Denmark. CE marked acc. to EN 60947-4/-5
				x	x	x		x					↓ Vd TÜV, Germany
							x	x	x	x			Det Norske Veritas, Norway
			x				x	x		x			Lloyds Register of Shipping, UK
x			x	x			x	x		x			F Germanischer Lloyd, Germany
			x				x	x	x	x			Bureau Veritas, France
x	x	x	x	x	x	x	x	x	x	x	x	x	Registro Italiano Navale, Italy
x	x		x				x	x	x	x			P Polski Rejestr Statków, Poland
x	x	x	x	x	x	x	x	x	x	x	x	x	RMRS, Russian Maritime Register of Shipping,
x	x		x				x	x	x	x			Nippon Kaiji Kyokai, Japan

Note: In addition we refer to the certificates, the copies of which can be ordered from Danfoss.

All RT are

- CE marked in accordance with EN 60947-4/-5 for sale in Europe
- Further, the RT 19, RT 30, RT 35, and RT 112 series is CE marked in accordance with PED 97/23/EC, category IV, safety equipment.

Pressure controls, type KRT

Technical data

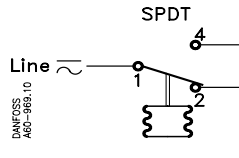
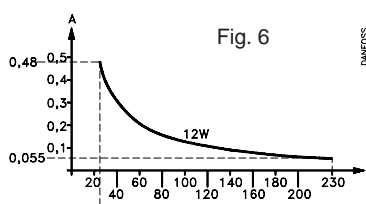
Designation	RT pressure controls	
Ambient temperature	In general -50 to 70°C VdJ -approved -40 to +70°C	
Contact system	 <p>Single-pole changeover switch (SPDT)</p>	
Contact load	Alternating current: AC-1: 10A, 400 V AC-3: 4A, 400 V AC-15: 3A, 400 V	
Contact material: AgCdO	Direct current: DC-13: 12 W, 230 V (see fig. 6)	
Special contact systems	Optional	
Cable entry	2 PG 13.5 for 6 - 14 mm diameter cables	
Enclosure	IP66 acc. to IEC 529 and DIN 40050. Units supplied with external reset IP54. The thermostat housing is made of bakelite acc. to DIN 53470. Cover is made of polyamide.	

Materials in contact with the medium

Material	Part	W. no.	DIN	RT 1	RT 1A	RT 5	RT 5A	RT 110	RT 112	RT 113	RT 116	RT 117	RT 121	RT 200/200L	RT 260A	RT 262A/262AL	RT 260AL	RT 265A	RT 263AL/266AL
Stainless steel 18/8	Bellows	1.4301	17440	x	x	x	x	x	x		x	x	x	x	x		x	x	x
Stainless steel 17/7	Spring	1.4568	17224	x						x		x	x	x					
Brass	Housing	2.0402	17660			x		x	x		x	x	x	x					
Brass	Bellows ring	2.0321	17660			x		x	x		x	x	x	x					
Free-cutting steel	Flare connect.	1.0718	1651	x															
Deep-drawn steel (nick.-plated surface)	Housing	1.0338	1623	x	x		x								x	x	x	x	x
Non-alli. carbon steel C20	Weld connect. for connection	1.0402	1652		x		x								x	x	x	x	x
Aluminium	Gasket	3.0255	1712		x		x			x					x	x	x	x	x
Case hardening steel C15	Weld connect. Bellows connet.	1.0401	1652																
Stainless steel	Spring guide + screw	1.4305	17440																
NBR-rubber	Diaphragm									x									
Deep-drawn steel (surface DIN 50961 weld conn. Fe/Zn 5C)	Diaphragm housing with welded connector	1.0338	1623							x									
Spring thread	Spring	1.1250	17223		x														

Materials in contact with the medium. Vd-J approved controls

Material	Part	W.no.	DIN	RT 19W B, S	RT 30AW AB, AS	RT 31W B, S	RT 32W B, S	RT 33B 35W	RT 112 W	RT 112	RT 116W
Stainless steel 18/8	Bellows	1.4301	17440	x	x	x	x	x	x	x	x
Stainless steel 17/7	Orifice	1.4305	17440	x	x						
Steel C15	Connector	1.0401	1652	x	x						
Deep-drawn steel + Ni	Bellows ring	1.0338	1623	x	x	x	x	x	x		
Stainless steel 17/7	Bellows spring	1.4568	17224		x			x			
Stainless steel	Ring	1.4305	17440		x						
Deep-drawn steel + Ni	Housing	1.0338	1623	x	x	x	x	x	x		
Stainless steel	Bellows connect.	1.4305	17440			x					
Stainless, weldable free-cutting steel	Connector	1.4301	17440			x	x	x	x		x
Deep-drawn steel + Sn	Spring guide	1.0338	1623					x			
Brass	Housing	2.0402	17660							x	x
Brass	Bellows ring	2.0321	17660							x	x

Dimensions and weight

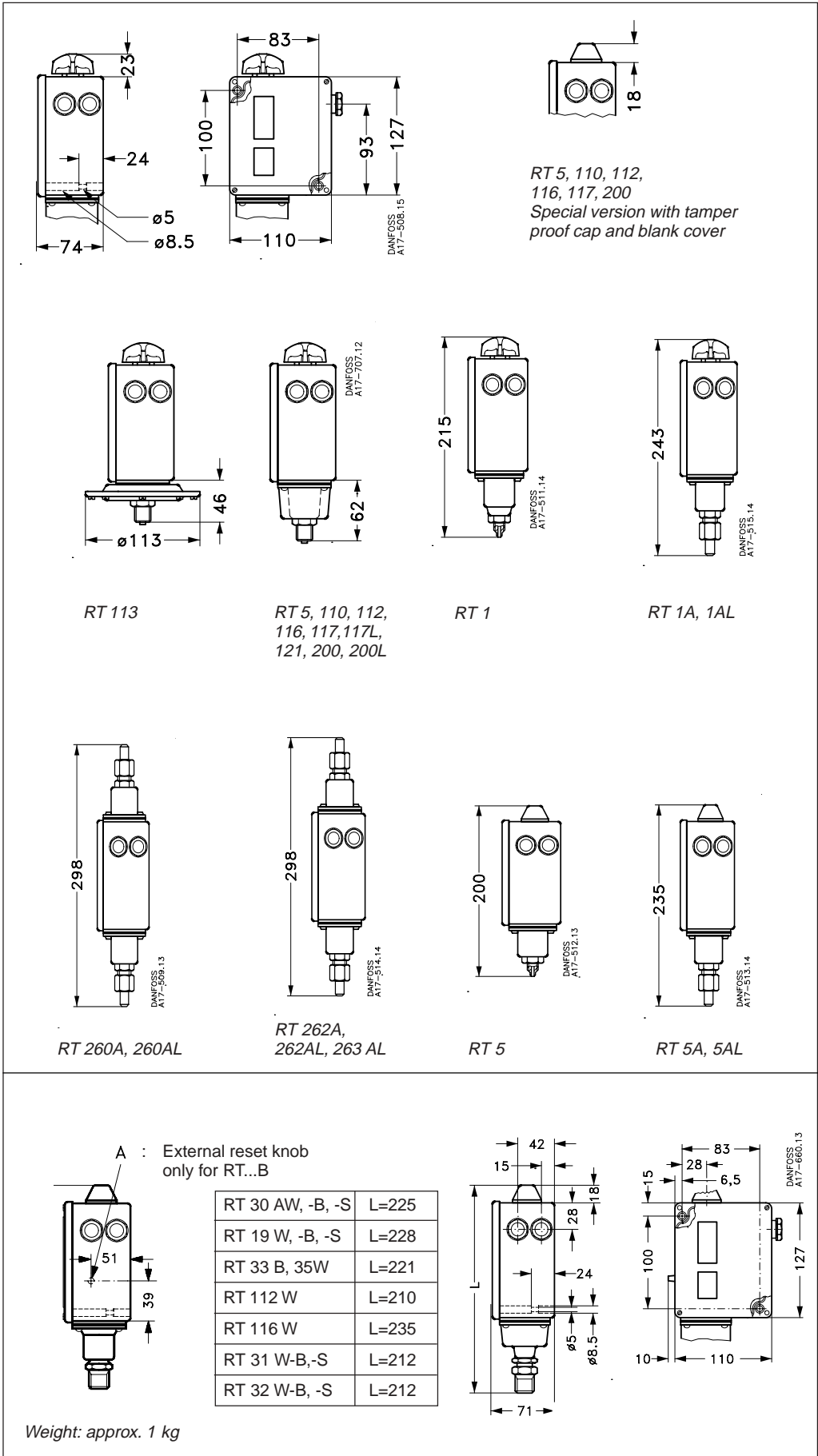

Installation

RT units have two mounting holes which become accessible when the front cover is removed. Units fitted with switch 017-0181*) must be installed with the setting knob upwards. When installing differential pressure controls, the low pressure side (marked LP) must be installed upwards. The other pressure controls in the RT series can be installed in any position, expect that on plant subjected to severe vibrations it is advantageous to have the screwed cable entry downwards.

*) Contact system with snap-action contact.
See spare parts and accessories, page 28

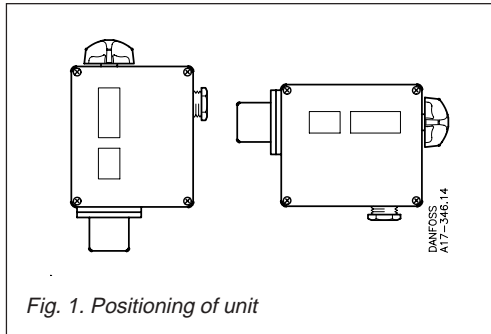

Fig. 1. Positioning of unit

Pressure connection

When fitting or removing pressure lines, the spanner flats on the pressure connection should be used to apply counter-torque.

Steam plant

To protect the pressure element against temperature in excess to the maximum temperature of the medium 150°C (RT 113 90°C), the insertion of water-filled loop is recommended.

Water systems

Water in the pressure element is not harmful, but if frost is likely to occur a water-filled pressure element may burst. To prevent this happening, the pressure control can be allowed to operate on an air cushion.

Media resistance

See table of materials in contact with the medium. If seawater is involved, diaphragm pressure controls types KPS 43, 45 and 47 are recommended.

Pulsations

The pressure control must be connected in such a way that the pressure element is affected by pulsations as little as possible. A damping coil can be inserted (see "Accessories"). With strongly pulsating media, diaphragm pressure controls types KPS 43, 45 and 47 can be advantageous.

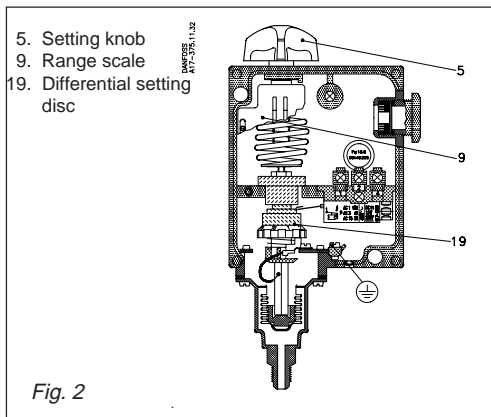

Fig. 2

Einstellung

Die Bereichseinstellung wird unter gleichzeitigem Ablesen der Skala (9) mit dem Einstellknopf (5) vorgenommen. Bei Druckschaltern mit Deckknopf ist für die Einstellung ein Werkzeug erforderlich. Für Geräte mit fester Differenz ist der Unterschied zwischen dem Ein- und Ausschaltdruck gegeben. Bei Geräten mit einstellbarer Differenz ist der Deckel zu entfernen. Die Differenzrolle (19) wird nach dem Diagramm eingestellt.

	1	2	3	4	5	6	7	8	9	10	
RT 1	0.5	0.7	0.9	1.1	1.3	1.5	1.6				bar
RT 1A (017-5001)											
RT 1A (017-5007)	1.3	1.5	1.7	1.9	2.1	2.3	2.4				bar
RT 5	1.2	1.6	2.0	2.4	2.8	3.2	3.6	4.0			bar
RT 5A											
RT 31W (017-5267)	0.3	0.4	0.5	0.6	0.7	0.8	0.9	1.0			bar
RT 32W (017-5247)	0.8	1.2	1.6	2.0	2.4	2.8	3.0				bar
RT 110	0.08	0.11	0.14	0.17	0.20	0.23	0.25				bar
RT 112	0.07	0.085	0.10	0.115	0.13	0.145	0.16				bar
RT 113	0.01	0.02	0.03	0.04	0.05						bar
	0.015	0.025	0.035	0.045							
RT 116	0.3	0.5	0.7	0.9	1.1	1.3					bar
RT 117	1.0	1.5	2.0	2.5	3.0	3.5	4.0				bar
RT 121	0.1	0.15	0.2	0.25	0.3	0.35	4.0				bar
RT 200	0.25	0.4	0.6	0.8	1.0	1.2					bar
	Min.	1	2	3	4	5	6	7	8	9	Max. 10

Fig. 3. Obtainable differential disc scale

Wahl der Differenz

Um einen zweckmäßigen automatischen Betrieb einer Anlage zu erreichen, ist eine angemessene Differenz erforderlich. Bei einer zu kleinen Differenz ergeben sich kurze Betriebszeiten mit dem Risiko der Pendelung. Bei einer zu großen Differenz treten erhebliche Druckschwankungen auf.

Differenzskalenwerte sind anleitend.

Function

a. RT 19, RT 30, and pressure controls with max. reset

When the pressure exceeds the set range value, contacts 1-4 make and contact 1-2 brake. The contacts changeover to their initial position when the pressure falls to the range value minus the differential (see fig. 4).

- I. Alarm for rising pressure given at the set range value.
 - II. Alarm for falling pressure given at the set range value minus the differential.
- Units with max. reset can only be reset at a pressure corresponding to the set range value minus the differential, or a lower pressure.

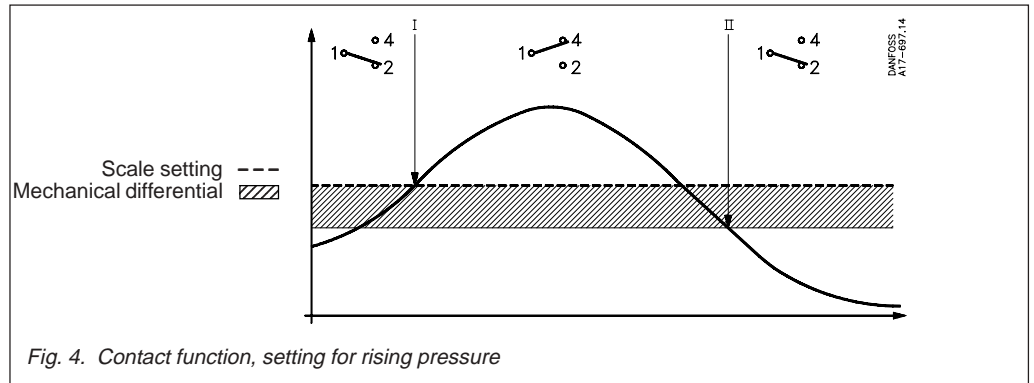

b. All other RT pressure controls

When the pressure falls to the set range value, contacts 1-2 make and contacts 1-4 brake. The contacts changeover to their original position when the pressure again rises to the set range plus the differential (see fig. 5).

- I. Alarm for falling pressure given at the set range value.
 - II. Alarm for rising pressure given at the set range value plus the differential.
- Units with min. reset can only be reset at a pressure corresponding to the set range value plus the differential.

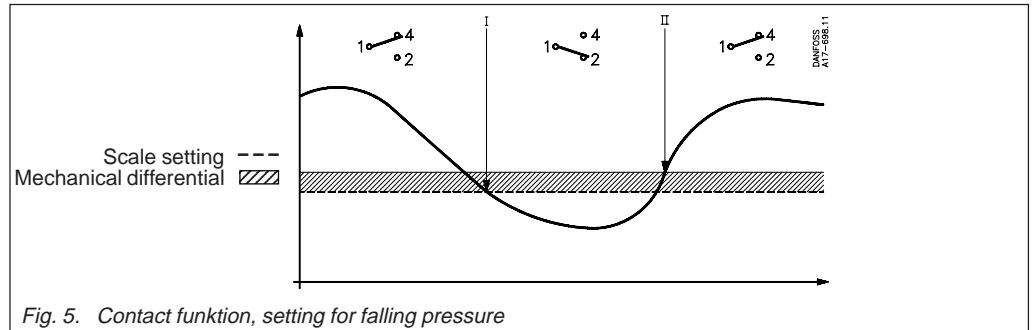

Example 1

An extra cooling water pump must start if the cooling water pressure falls below 6 bar, and must stop when the pressure exceeds 7 bar. Choose an RT 116 with a range of 1-10 bar and an adjustable differential of 0.2-1.3 bar. The start pressure of 6 bar must be set on the range scale. The differential must be set as the difference between the stop pressure (7 bar) and the start pressure (6 bar) = 1 bar. According to fig. 3, the differential setting disc must be set on 8.

The range is 5-25 bar and the differential is fixed at approx. 1 bar. The range scale must be set at 17 bar. After cut-out of the burner, manual reset is possible only when the pressure had fallen to the setting of 17 bar minus the differential: in this case, 16 bar and below.

Example 2

The burner on a steam boiler must cut out when the pressure exceeds 17 bar. Automatic restart must not occur. Choose an RT 19B with external reset. If extra safety is demanded, an RT 19S with internal max. reset can be used.

Example 3

The min. permissible lubricating oil pressure for a gear is 3 bar. Reset must not be possible until the reason for oil pressure failure has been investigated. Choose an RT 200 with min. reset. The range value must be set while reading the range scale. Manual reset is possible only when the pressure has reached 3.2 bar (the differential is fixed at 0.2 bar or higher).

**Function description
for KRT units
DIN approval**

Fail-safe function for falling pressure

Fig. 5a shows a cross-section of a bellows element for the RT 32W with fail-safe function for falling pressure. On rising pressure the contact arm is actuated to break the connection between terminals 1 and 2.

On falling pressure the contact arm is actuated to break the connection between terminals 1 and 4. If a defect occurs in the bellows the setting spring actuates the contact arm to break the connection between terminals 1 and 4, as in the case of falling pressure. This will occur irrespective of the pressure on the bellows.

Fail-safe function for rising pressure

Fig. 5b shows a cross-section through a bellows element for the RT 30W with fail-safe for rising pressure. On rising pressure the contact arm is actuated to break the connection between terminals 1 and 2. If a defect occurs in the inner bellows the pressure is led to the outer bellows. The outer bellows has an area three times as large as the inner bellows. The connection between terminals 1 and 2 becomes broken.

If a defect occurs in the outer bellows, there will be atmospheric pressure in the gap between the two bellows. This actuates the contact system to break the connection between terminals 1 and 2. The important factor with the double bellows design is the vacuum between the two bellows, and that in case of bellows break, no media will leak into the environment.

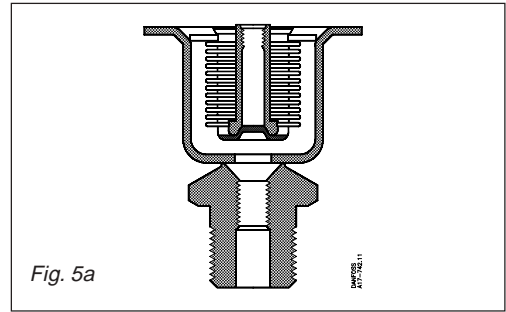

Fig. 5a

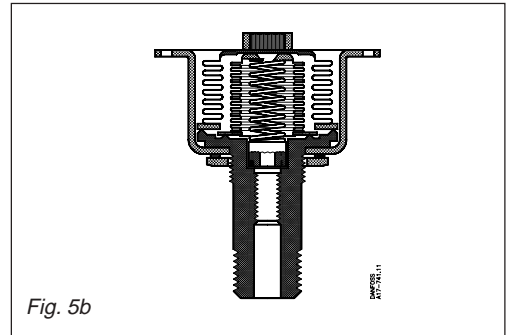

Fig. 5b

**Pressure controls for liquid
level control RT 113**

The RT 113 pressure control can be used to control the liquid level in open tanks. Fig. 6 shows in principle, four different types of installation.

1. With air bell (see "Accessories")

For control purpose, the air bell should be installed 20 to 40 mm below the lowest liquid level. In addition, the tube between the RT 113 and the air bell must be absolutely airtight. If only an indication is required, the bell can be placed 100 mm below the max. level. The RT 113 must be set at 0 cm wg and the differential disc on 1.

2. Connection to the side of the tank with the RT 113 above the liquid level

The horizontal tube A must have a certain length in relation to the vertical tube B in order to ensure reliable control. The length of A can be found from fig. 7, using B and the range setting pressure C.

3. Connection to the side of the tank with the RT 113 below the liquid level

Where possible, this form of connection should be used. If an air-absorbing liquid like oil is involved, it is preferable to 1 and 2. The resulting range setting is the distance from the liquid surface to the centre of the diaphragm housing.

4. Connection in the tank with the RT 113 above the liquid level

This method is for use with air-absorbing liquids where connection type 3 is not possible. The shortest horizontal tube length is determined as described in 2. A shut-off valve is installed between the oil tank and water reservoir shown so that impurities can be drained from the water reservoir through a bottom drain plug. Fresh water can then be poured into the reservoir through a filling connector in its top.

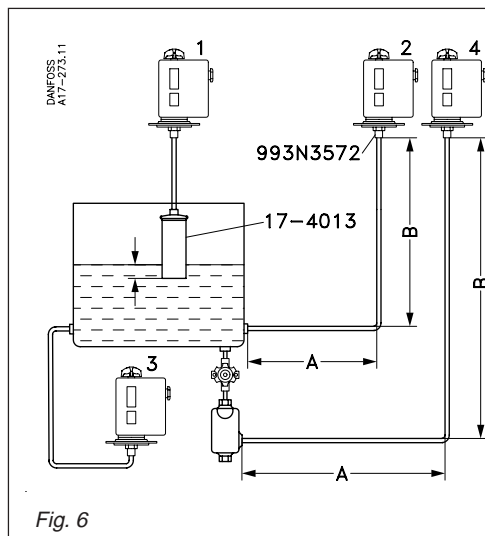

Fig. 6

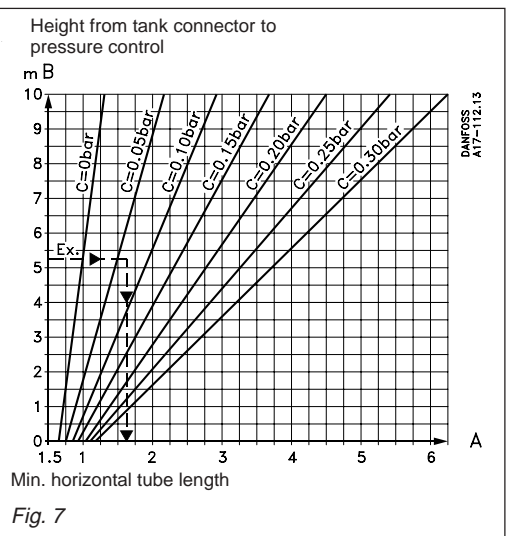
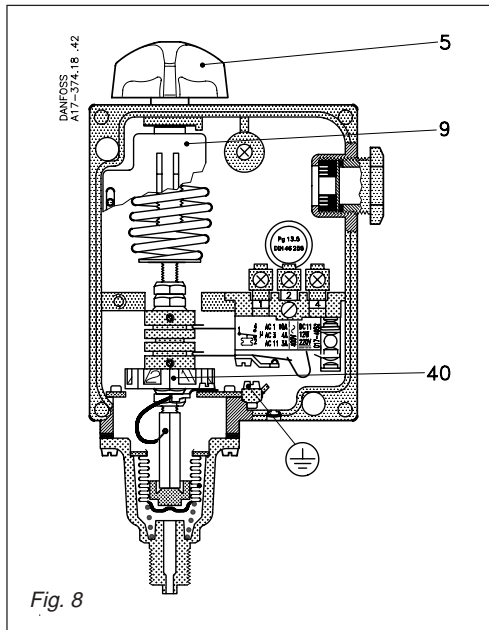

Fig. 7

Pressure controls with adjustable neutral zone, type KRT-L

Application



RT-L pressure controls are fitted with a switch with an adjustable neutral zone. This enables the units to be used for floating control. The terminology involved is explained below.

Floating control

A form of discontinuous control where the correcting element (e.g. valve, damper, or similar) moves towards one extreme position at a rate independent of the magnitude of the error when the error exceeds a definite positive value, and towards the opposite extreme position when the error exceeds a definite negative value.

Hunting

Periodic variations of the controlled variable from the fixed reference.

Neutral zone

The interval in the controlled variable in which the correcting element does not respond (see fig. 13).

The contact system in neutral zone units cannot be exchanged, as the contact system adjustment is adjusted to the other parts of the unit.

Setting of neutral zone

The range is set using the setting knob (5) fig. 8 while reading the range scale (9). The pressure set is the break pressure for contacts 1-4 (see fig. 13).

The required neutral zone can be found in the diagram for the unit concerned. The position at which the neutral zone disc (40) must be set can be read from the lower scale in the diagram. The function can be seen in fig. 13.

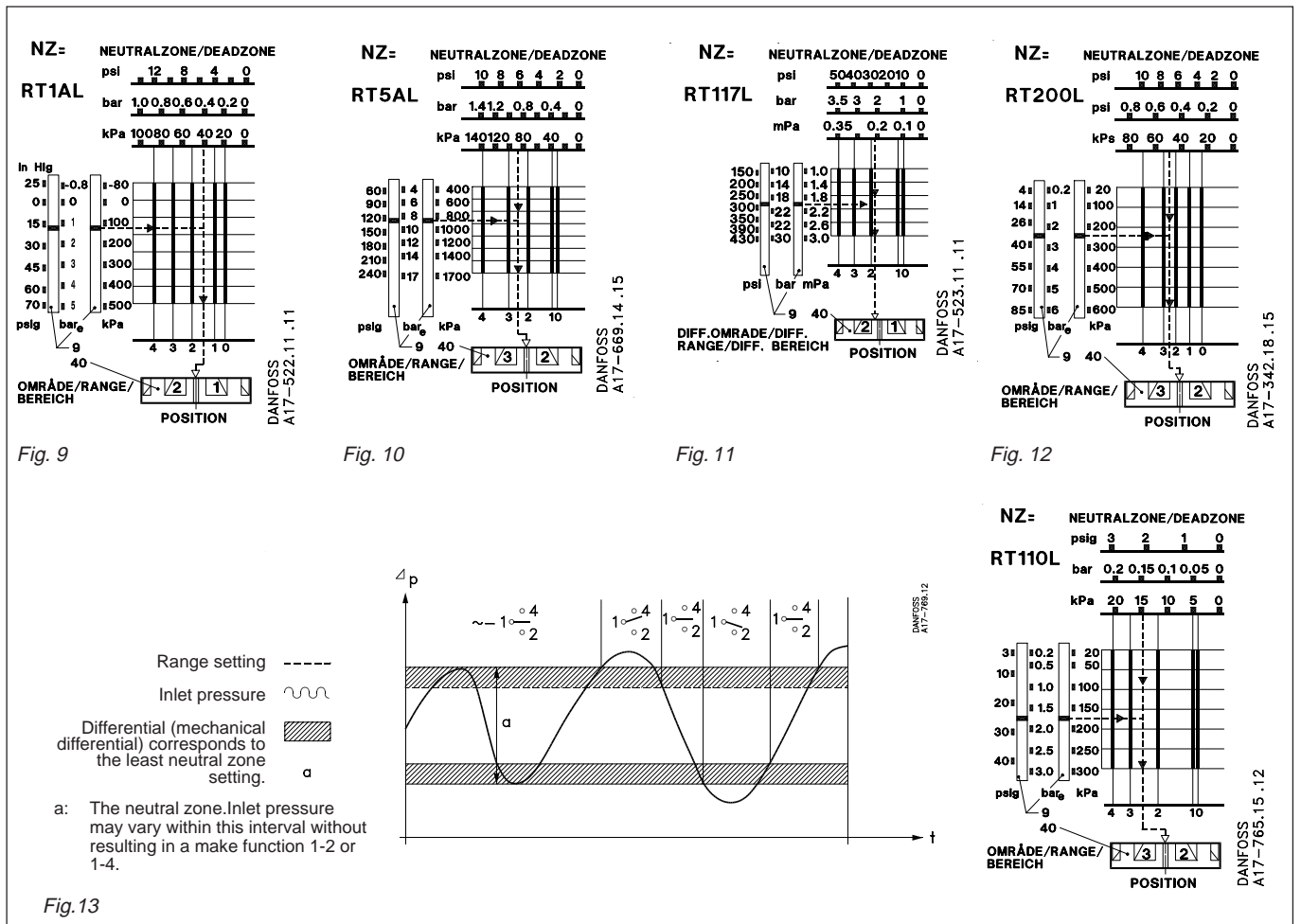

Example

Together with a VLT® static frequency converter, RT 200L neutral zone pressure controls can be used for the infinite control of a pump in, for example, a pressure boosting plant.

In this case, the pump must be up and down-regulated at 32 and 25 m wg.

The RT 200L must be set using the setting knob (5) fig. 8 page 11 at 3.5 bar (35 m wg) minus the fixed differential of 0.2 bar.

The range setting is $3.5 - 0.2 = 3.3$ bar.

The neutral zone, $35 - 32 = 3$ m wg, corresponding to 0.3 bar, must be set on the neutral zone disc (40) fig. 8 page 11. According to the diagram fig. 12 the disc setting is 1 or just over. A more accurate setting can be obtained by using the test setup shown in fig. 14.

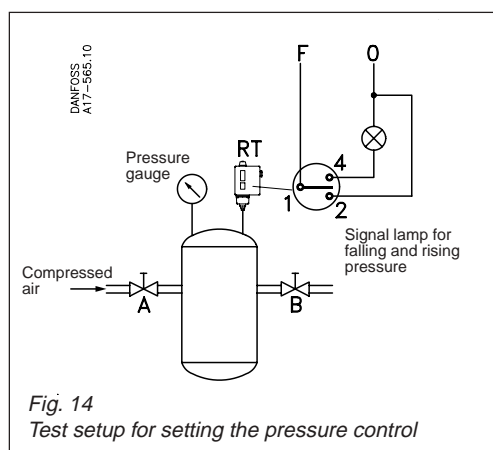

Differential pressure control, type KRT

Application

Control and monitoring of pressure differentials
 A differential pressure control is a pressure controlled switch that cuts in and cuts out the current dependent on the pressure differential between the

counteracting bellows elements and the set scale value. This unit is also available with an adjustable neutral zone (like the RT-L which is described on page 11.)

Setting

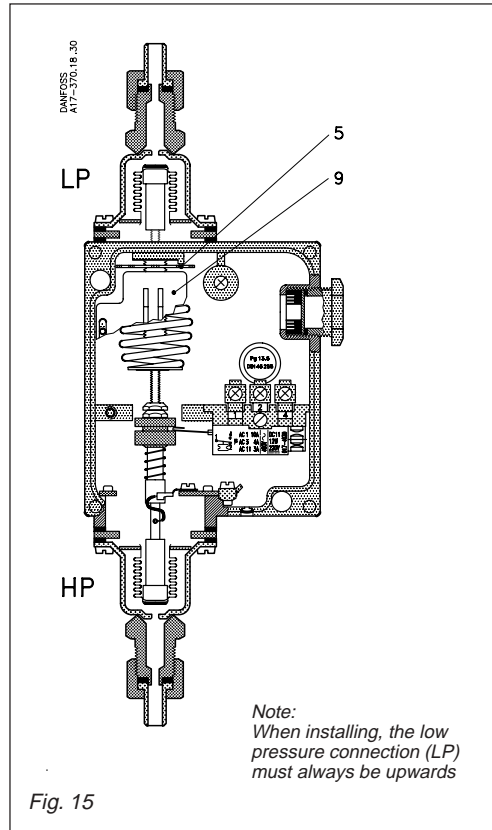

- 5. Setting disc
- 9. Range scale

The setting disc (5) becomes accessible when the front cover is removed. The differential pressure is set by turning the disc with a screwdriver while reading the scale (9).

For differential pressure controls with a changeover contact system, the contact differential is given as the differential pressure controls have a fixed differential.

In units with an adjustable neutral zone, the neutral zone disc must also be set. See diagram in fig. 16.

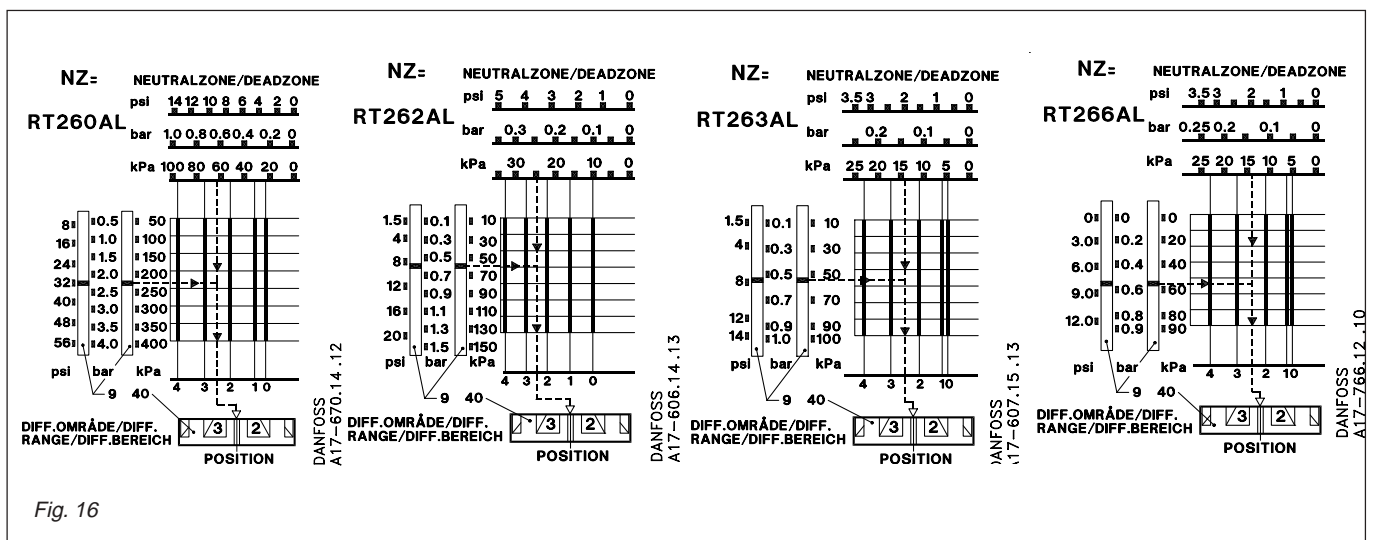

Function

a. Units with changeover switch (SPDT)

If the differential pressure falls below the set value, contacts 1-2 make and contacts 1-4 break. Contacts 1-2 break again and contacts 1-4 make when the differential pressure has risen to the set range value plus the fixed contact differential.

- I. Contacts make when differential pressure falls below the range scale setting.
- II. Contacts make when pressure rises above the range scale setting plus the fixed mechanical differential.

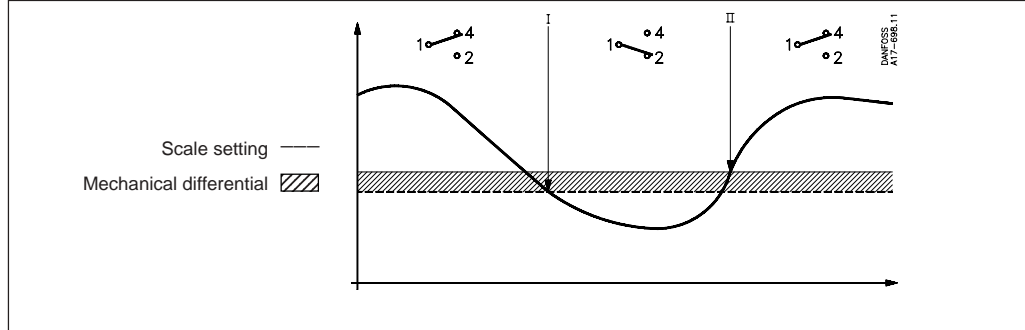

b. Units with adjustable neutral zone (SPDTNP)

If the differential pressure rises above the set value plus the differential, contacts 1-4 make. If the pressure falls by the amount of the differential (which is fixed in this unit), contacts 1-4 break. If the pressure falls to the neutral zone minus the differential, contacts 1-2 make. When the differential pressure rises again by an amount corresponding to the differential, contacts 1-2 break again.

The contact function can be summed up as follows:

- I. Setting disc set for falling differential pressure.
- II. Neutral zone disc set for rising differential pressure.

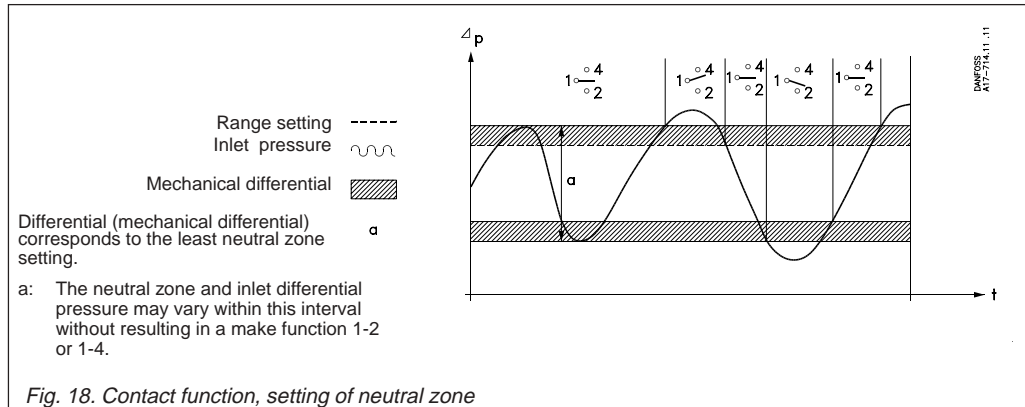

Fig. 18. Contact function, setting of neutral zone

Example 1

When the differential pressure exceeds 1.3 bar, a filter needs cleaning. The static pressure over the filter is 10 bar. According to the ordering table on page 4, the choice is an RT 260A (the RT 262A has a max. operating pressure on the low pressure side (LP) of 6 bar and is therefore not suitable for this application). Setting: Since a signal is required for rising differential pressure, the setting becomes $1.3 - 0.3 \text{ bar} = 1.0 \text{ bar}$.

Example 2

The speed of a circulation pump must be controlled to give a constant differential pressure of 10 m wg in a heating plant. The static plant pressure is 4 bar. The choice is an RT 262AL. The differential disc (5) fig. 15 page 13, must be set at 1 bar (10 m wg) minus the fixed differential of 0.1 bar, i.e. 0.9 bar. The neutral zone disc is factory-set (marked in red).