

Sight Flow Indicators for Liquids

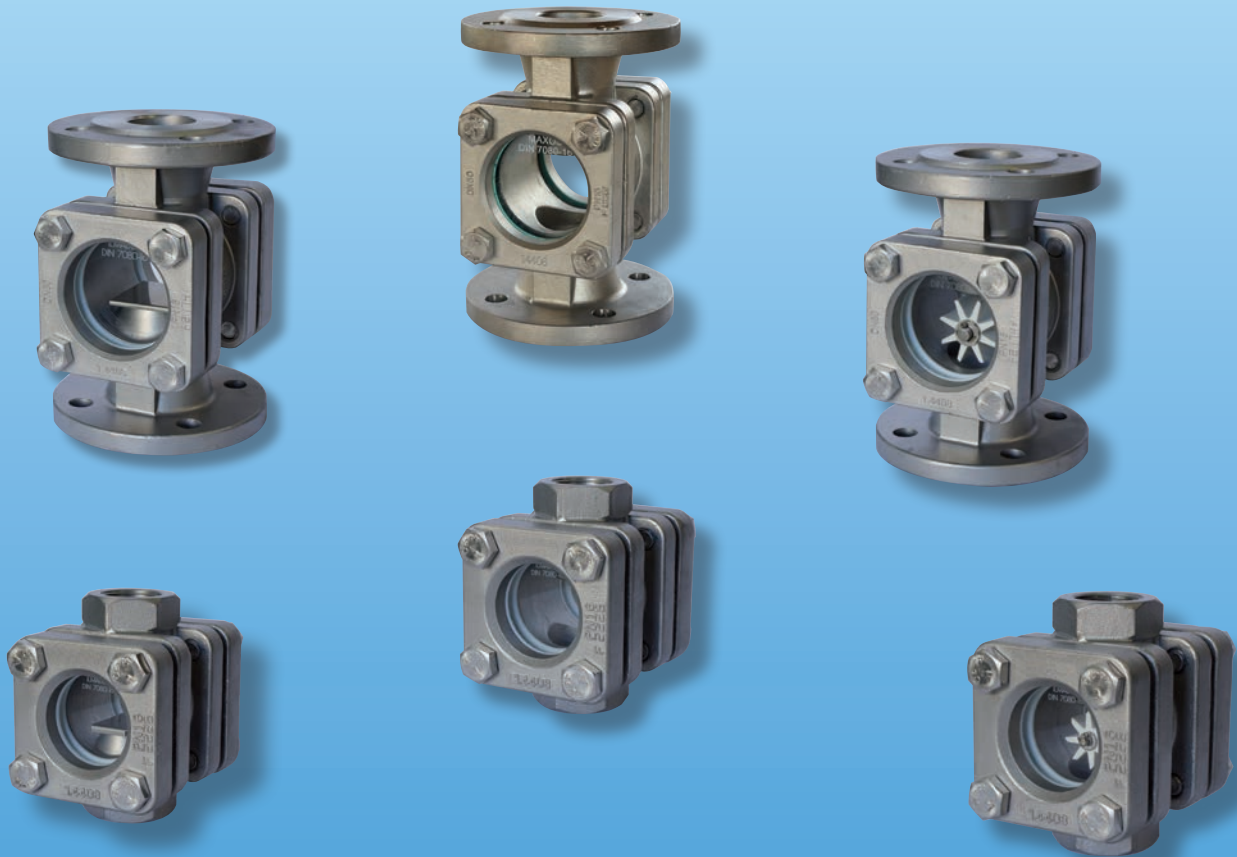

measuring
•
monitoring
•
analyzing

DA Series



- p_{max} : 230 PSIG (Optional 360 or 580 PSIG)
- t_{max} : 250 or 300 °F, Depending on Model (Optional 530 °F)
- Connections: 1/4"... 2" NPT, 1/2"... 8" ANSI Flange
- Material: Cast Iron, Cast Steel, or Stainless Steel
- Graphite Seals



Contact:
Industrial Process Measurement, Inc.
3910 Park Avenue, Unit 7
Edison, NJ 08820
732-632-6400
support@instrumentation2000.com
<http://www.instrumentation2000.com>



Models, Materials, and Mounting Positions

Model DAK with Flap Indication

Component	DAK-21..	DAK-12../22..	DAK-13../23..
Flap	316-Ti Stainless Steel		
Housing	Grey Cast Iron 0.6025	316 Stainless Steel (1.4408)	Cast Steel 1.0619
Cover Plates	Grey Cast Iron 0.6025/ S235JRG2	316 Stainless Steel (1.4408)/ 316 Stainless Steel (1.4301)	Cast Steel 1.0619/ S235JRG2
Sight Glass	Soda-Lime Glass DIN 8902 (up to 300 °F, 230 PSI max) Optional Borosilicate Glass DIN 7080 (up to 530 °F max)		
Screws	Zinc-plated Steel	Stainless Steel	Zinc-plated Steel
Seals	Graphite (Others upon Request)		
Mounting Position	Horizontal or Vertical with Flow from Bottom to Top		
Operating Pressure:	230 PSIG max (Optional 360 PSIG or 580 PSIG)		



Model DAR with Rotor Indication

Component	DAR-21..	DAR-12../22..	DAR-13../23..
Rotor:	Plastic (up to 250 °F) or Option "R" PTFE up to 500 °F (Nominal Size 2" and above: PTFE Standard)		
Housing:	Grey cast iron 0.6025	316 Stainless Steel (1.4408)	Cast Steel 1.0619
Cover Plates:	Grey Cast Iron 0.6025/ S235JRG2	316 Stainless Steel (1.4408)/ 316 Stainless Steel (1.4301)	Cast Steel 1.0619/ S235JRG2
Sight Glass:	Soda-Lime Glass DIN 8902 (up to 250 °F, 230 PSI max) Optional Borosilicate Glass & PTFE Rotor DIN 7080 (up to 500 °F max)		
Screws:	Zinc plated Steel	Stainless Steel	Zinc-plated Steel
Sealing:	Graphite (Others on Request)		
Mounting Position:	Universal		
Operating Pressure:	230 PSIG max (Optional 360 PSIG or 580 PSIG)		



Model DAT with Drip Indication

Component	DAT-21..	DAT-12../22..	DAT-13../23..
Housing*:	Grey Cast Iron 0.6025	316 Stainless Steel (1.4408)	Cast Steel 1.0619
Cover Plates:	Grey Cast Iron 0.6025/ S235JRG2	316 Stainless Steel (1.4408)/ 316 Stainless Steel (1.4301)	Cast Steel 1.0619/ S235JRG2
Sight Glass:	Soda-Lime Glass DIN 8902 (up to 300 °F, 230 PSI max) Optional Borosilicate Glass DIN 7080 (up to 530 °F max)		
Screws:	Zinc-plated	Stainless Steel	Zinc-plated Steel
Seals:	Graphite (Others on Request)		
Mounting Position:	Any Position, Preferably Vertical, Flow from Top		
Operating Pressure:	230 PSIG max (Optional 360 PSIG or 580 PSIG)		



* Threaded connections up to 1/2": inlet with half face plate; all others: drip tube



Order Details: Threaded Connections (Example: **DAK-1201H N08**)

Type of Indication	Body Material	Nominal Size	Connection (NPT)	Options
DAK-1.. = Flap	..2.. = Stainless Steel	..01H.. = 1/4"	..N08	..B = Borosilicate Glass, 230 PSIG max ..P = Borosilicate Glass, 360 PSIG max ..Q = Borosilicate Glass, 580 PSIG max ..R ¹⁾ = PTFE Rotor
		..02H.. = 3/8"	..N10	
..03H.. = 1/2"		..N15		
DAR-1.. = Rotor		..04H.. = 3/4"	..N20	
	..05H.. = 1"	..N25		
DAT-1.. = Drip Tube	..3.. = Cast Steel	..06H.. = 1-1/4"	..N32	
		..07H.. = 1-1/2"	..N40	
		..08H ²⁾ .. = 2"	..N50	

¹⁾ Only for model DAR, not for models DAK or DAT.
²⁾ Model DAR with nominal size 2" comes standard with PTFE rotor.

Order Details: Flange Connections (Example: **DAK-2201H A15**)

Type of Indication	Body Material	Nominal Diameter	Connection ANSI Flange (Class 150 lb)	Options
DAK-2.. = Flap	..1 ³⁾ .. = Cast Iron	..01H.. = 1/2"	..A15	..B = Borosilicate Glass, 230 PSIG max (Class 150 lb) ..P = Borosilicate Glass, 360 PSIG max (Class 300 lb) for Stainless Steel or Cast Steel Bodies Only ..Q = Borosilicate Glass, 580 PSIG max (Class 300 lb) for Stainless Steel or Cast Steel Bodies Only ..R ¹⁾ = PTFE Rotor
		..02H.. = 3/4"	..A20	
		..03H.. = 1"	..A25	
DAR-2 ²⁾ .. = Rotor		..04H.. = 1-1/4"	..A32	
		..05H.. = 1-1/2"	..A40	
DAT-2.. = Drip Tube	..2.. = Stainless Steel	..06H.. = 2"	..A50	
		..07H.. = 2-1/2"	..A65	
	..3.. = Cast Steel	..08H.. = 3"	..A80	
		..09H ⁶⁾ .. = 4"	..A1H	
		..10H ⁵⁾⁶⁾ .. = 5"	..A1Z	
..11H ⁴⁾⁵⁾⁶⁾ .. = 6"	..A1F			
..12H ⁴⁾⁵⁾⁶⁾ .. = 8"	..A2H			

¹⁾ Only for model DAR, not for models DAK or DAT
²⁾ Model DAR with nominal diameter 2" and above come standard with PTFE rotor.
³⁾ Options "P" and "Q" (300 lb ANSI Flange) are not available for Cast Iron Models
⁴⁾ Models come standard with Borosilicate Glass
⁵⁾ Not available with Option "P", 360 PSIG only possible for 4" and under
⁶⁾ Not available with Option "Q", 580 PSIG only possible for 3" and under



**Dimensions for Models with a Threaded Connection:
for Pressure Rating 230 PSIG (360/580 PSIG on Request)**

NPT	BL	H	SW	W	d1	d2	Glass Thickness (S) 230 PSIG	Approx. Weight
1/4" 3/8" 1/2"	3.94"	4.33"	1.42"	2.76"	1.26"	1.77"	0.39"	4.85 lbs
3/4"	4.73"	4.72"	1.81"	3.35"	1.89"	2.48"	0.39"	7.50 lbs
1"	4.73"	4.72"	1.81"	3.35"	1.89"	2.48"	0.39"	7.50 lbs
1-1/4"	6.30"	6.10"	2.95"	4.33"	2.56"	3.15"	0.47"	15.43 lbs
1-1/2"	6.30"	6.10"	2.95"	4.33"	2.56"	3.15"	0.47"	15.43 lbs
2"	9.06"	7.09"	3.54"	4.72"	3.15"	3.94"	0.59"	22.49 lbs

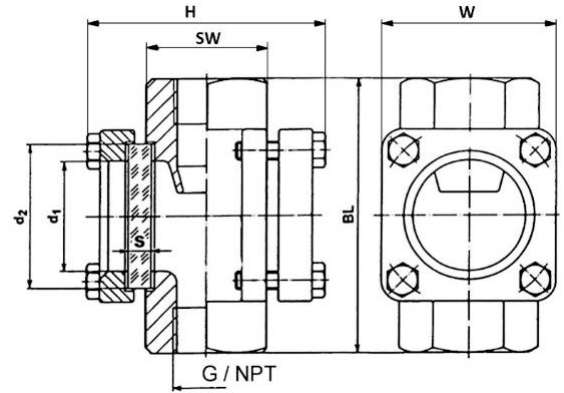

Dimensions for Pressure Rating According to ANSI 150/300 lbs

Size	H	W	D		BL	d1	d2	Glass Plate S		Approx. Weight (150 lb***)	
			150 lbs	300 lbs				150 lb	300 lb	DAx-21..	DAx-22../23..
1/2"	3.74"	2.76"	3.50"	3.75"	5.12"	1.26"	1.77"	0.39"	0.39"	7.94 lbs	7.94 lbs
3/4"	3.74"	2.76"	3.86"	4.62"	5.91"	1.26"	1.77"	0.39"	0.39"	8.82 lbs	8.82 lbs
1"	4.53"	3.35"	4.25"	4.87"	6.30"	1.89"	2.48"	0.39"	0.59"	13.23 lbs	13.89 lbs
1-1/4"	4.53"	3.35"	4.65"	5.25"	7.09"	1.89"	2.48"	0.39"	0.59"	15.43 lbs	16.32 lbs
1-1/2"	5.32"	4.33"	5.0"	6.13"	7.87"	2.56"	3.15"	0.47"	0.79"	22.05 lbs	23.37 lbs
2"	6.30"	4.73"	5.98"	6.50"	9.06"	3.15"	3.94"	0.59"	0.98"	29.10 lbs	31.75 lbs
2-1/2"	7.28"	6.90"	7.01"	7.50"	11.42"	3.15"	3.94"	0.59"	0.98"	48.72 lbs	52.91 lbs
3"	8.27"	7.48"	7.52"	8.25"	12.20"	3.94"	4.92"	0.79"	1.18"	65.92 lbs	69.67 lbs
4"	9.84"	8.27"	8.98" *	10.00"	13.78"	4.92"	5.91"	0.98"	-	84.66 lbs	91.93 lbs
5"	10.43"	9.25"	10.00" *	11.00"	15.75"	5.91"	6.89"	0.98"	-	103.62 lbs	104.94 lbs
6"	11.42"	10.24"	10.98"	12.50"	18.90"	6.89"	7.87"	1.18" **	-	130.07 lbs	149.03 lbs
8"	14.17"	11.22"	13.50" *	15.00"	23.62"	6.89"	7.87"	1.18" **	-	216.05 lbs	260.15 lbs

* Cast Iron versions diameter D according to DIN

** Borosilicate glass only as standard

*** 300 lb weights upon request

