

**IPAQ®**



# R520 / R520N / R520X / R520S / R520XS

## HART Compatible, Universal, Dual-input 2-wire Transmitters



The 520 transmitters are universal, isolated, dual-input temperature transmitters with additional voltage and resistance input. Typical characteristics are the high accuracy, reliable measurements, product safety and user efficiency.

The transmitters are compatible with the HART 6 protocol offering extended diagnostic information.

### High Measurement Accuracy

Long-term stability	Drift over 5 years is the maximum of $\pm 0.05$ °C or $\pm 0.05$ % of span
High precision	Example Pt 100: $\pm 0,1$ °C or 0,05 % of span
Low temperature drift	$\pm 0.005$ % of span per °C

### High Reliability

Dual Sensor Input	With for example Pt100, 2- 3- & 4-wire, T/C, Resistance and Voltage
Sensor Drift Detection	One sensor with double elements, monitoring the temperature difference
Sensor Back-up	Automatic switchover to backup sensor
Robust design	10g vibrations, robust terminals

### High Safety

SIL 2	According to IEC 61508-2
NAMUR	Compliant to NE 21, NE 43, NE 53, NE 89 and NE 107
EX-approvals	ATEX: Intrinsically safe and Non-incendive FM, CSA, IECEx, GOST in preparation

### High User Efficiency

Easy configuration, installation and maintenance with ConSoft, HART6 Protocol, EDD plus DTM/FDT enabled systems

## Features of the 520 transmitters

### Basic accuracy and long-term stability

The combination of a high-efficient 50-point linearization and an electronic design based on the most precise and "zero-drift" technology results in a high basic accuracy and excellent long-term stability. The drift over 5 years is guaranteed to maximum of  $\pm 0.05$  °C or  $\pm 0.05$  % of the measuring span.

### Ambient temperature stability

Features like continuous self-calibration of the input AD converter in every measurement cycle and a "zero-drift" current generation of the output DA converter have strongly reduced the ambient temperature influence to a minimum.

### Customized linearization

For resistance and mV inputs, the 50-point Customized Linearization can provide a correct process value, in a choice of engineering units, for a sensor with non-linear input/output relation.

### Adjustable filtering

For smoothing down instabilities on the input, an additional filter, with an adjustable filtering level can be activated.

### Sensor matching doubles the accuracy

This function compensates for deviations (compared to actual standard values) in connected sensors. A reduction of the total measurement error, for the sensor/transmitter combination, of more than 50 % is typical.

### Sensor backup

Dual-sensor input allows for backup between two sensors. Should a lead break or short-circuit be detected on one of the sensor circuits, an automatic switchover to the intact sensor will occur.

### Single-sensor or dual-sensor input

The dual-sensor input for RTD, Resistance or Thermocouple allows for 3 output alternatives, each represented by a 4-20 mA signal:

1. The measured value of sensor 1
2. The measured value of sensor 2
3. A calculated value from sensor 1 and 2, e.g. Difference, Average, Minimum and Maximum.

### Sensor drift monitoring

If an RTD or thermocouple with double sensor elements is used, the 520 transmitters can detect sensor drift by checking the reading from both elements. If the difference is above a user-defined level, this will be indicated in ConSoft and with a diagnostic HART message, and the output signal can be forced upscale or downscale.

### Sensor isolation monitoring

The isolation resistance of thermocouples and RTD's as well as the cabling between sensor and transmitter is being monitored. If the isolation is below a user-defined level, this will be indicated in ConSoft and with a diagnostic HART message, and the output signal can be forced upscale or downscale. This feature requires an extra lead inside the thermocouple or RTD.

### Measurements with RTD's and potentiometers

The 520 transmitters accept inputs from standardized Platinum RTDs acc. to IEC 60751 and JIS C 1604, Nickel RTD's acc. to DIN 43760 and Cu10 acc. to Edison Cu Windings No. 15.

Input for plain resistance, such as potentiometers, up to 4000  $\Omega$  is available.

2-, 3- or 4-wire connection can be chosen for single-input and dual-input [See Input connections below].

### Measurements with Thermocouples and plain voltage

The 520 transmitters accept inputs from 10 types of standardized thermo-couples as well as plain mV input up to 1000 mV.

For T/C input, the CJC [Cold Junction Compensation] is either fully automatic, by means of an internal accurate sensor, external with Pt100 sensor or fixed by entering an external CJ temperature.

### SIL 2 compliance

Based on a hardware assessment according to IEC 61508-2, consisting of a FMEDA done by Exida, R520S and R520XS are suitable for use in SIL 2 rated Safety Instrumented Systems (SIS). See the Safety Manual for details.

### ConSoft configuration software

The PC configuration software, ConSoft, is a versatile and user-friendly tool for transmitter configuration, loop check-up and sensor diagnostics. It runs on Windows NT, 2000, XP, Vista and Windows 7. All features described in this data sheet are handled in a simple and fail-safe way.

ConSoft is part of the complete Configuration Kit ICON, which also contains a USB Interface and necessary cables.

### Configuration alternatives

In addition to ConSoft (see above) the following configuration alternatives are available:

Hand held communicator, e.g. FC375 (Emerson)

Management systems, e.g. AMS (Emerson) and PDM (Siemens)

EDD enabled systems – "520 EDD" available on our website.

DTM/FDT enabled systems – "520 DTM" available on our website.

### HART 6 compliance

The 520 transmitters are fully compliant with the HART 6 protocol as well as the previous HART 5.

HART 6 offers the possibility to receive diagnostic information such as sensor errors or sensor conditions, input wiring resistance too high, sensor backup mode, transmitter error etc. See User Instructions for details.

## Specifications

### Input RTD

Pt100	(IEC 60751, $\alpha=0.00385$ )	-200 to +850 °C
Pt X ( $10 \leq X \leq 1000$ )	(IEC 60751, $\alpha=0.00385$ )	Corresp. to max. 4 000 $\Omega$
Pt100	(JIS C 1604, $\alpha=0.003916$ )	-200 to +850 °C
Ni100	(DIN 43760)	-60 to +250 °C
Ni120	(Edison Curve No. 7)	-60 to +250 °C
Ni1000	(DIN 43760)	-50 to +180 °C
Cu10	(Edison Copper Windings No. 15)	-50 to +200 °C
Input connection		See "Input connections" below
Sensor current		$\leq 300 \mu\text{A}$
Maximum sensor wire resistance	3- and 4-wire connection	50 $\Omega$ /wire
	2-wire connection	Compensation for 0 to 40 $\Omega$ loop resistance

### Input Resistance / Potentiometer

Range, resistance	0 to 4000 $\Omega$
Range, potentiometer	100 to 4000 $\Omega$
Zero adjustment	Within range
Minimum span	10 $\Omega$
Customized linearization	Up to 50 points
Sensor current	$\leq 300 \mu\text{A}$
Input connections	See "input connections" below
Maximum sensor wire resistance	50 $\Omega$ / wire

### Input Thermocouple

T/C B	Pt30Rh-Pt6Rh (IEC 60584)	400 to +1800 °C
T/C C	W5-Re (ASTM E 988)	0 to +2315 °C
T/C D	W3-Re (ASTM E 988)	0 to +2315 °C
T/C E	NiCr-CuNi (IEC 60584)	-200 to +1000 °C
T/C J	Fe-CuNi (IEC 60584)	-200 to +1000 °C
T/C K	NiCr-Ni (IEC 60584)	-200 to +1350 °C
T/C N	NiCrSi-NiSi (IEC 60584)	-250 to +1300 °C
T/C R	Pt13Rh-Pt (IEC 60584)	-50 to +1750 °C
T/C S	Pt10Rh-Pt (IEC 60584)	-50 to +1750 °C
T/C T	Cu-CuNi (IEC 60584)	-200 to +400 °C
Input impedance		>10 M $\Omega$
Input connections		See "Input connections" below
Maximum wire loop resistance		10000 $\Omega$ (Including T/C sensor)
Cold Junction Compensation (CJC)		Internal, external (Pt100) or fixed

### Input Voltage

Range	-10 to +1000 mV
Zero adjustment	Within range
Minimum span	2 mV
Customized linearization	Up to 50 points
Input impedance	>10 M $\Omega$
Input connections	See "Input connections" below
Maximum wire loop resistance	500 $\Omega$

### Double inputs for RTD and Thermocouple

Measure mode	Single temperature	T1 or T2
	Differential temperature	T1 - T2 or T2 - T1
	Average temperature	$0.5 * (T1 + T2)$
	Minimum temperature	Lowest of T1 and T2
	Maximum temperature	Highest of T1 and T2
Sensor Backup	Single or Average mode	Failure of one sensor activates automatic switchover to the other sensor
Sensor Drift Monitoring	Single or Average mode	Adjustable acceptance level of the differential temperature of sensor 1 and 2

### Output

Output signal	4-20 mA, 20-4 mA or customized. Temperature linear for RTD & T/C
HART protocol	HART 6
HART physical layer	FSK 1200
Representation	T1 or T2 or Difference, Average, Min or Max of T1 and T2
Update time	Single input: ~300 ms; Double input: ~600 ms
Resolution	1.5 $\mu$ A
Adjustable output filtering	Level 1 to 7
Permissible load	635 $\Omega$ @ 24 VDC incl. 250 $\Omega$ loop resistance
NAMUR Compliance	Current limitations and failure currents acc. to NAMUR, NE 43

### Sensor Isolation Monitoring

Detection of low sensor isolation	Adjustable acceptance level for minimum isolation
-----------------------------------	---

### Sensor Drift Monitoring

Detection of deviation between two sensors	Adjustable acceptance level for maximum deviation
--	---

### Sensor Failure Effects

Output control acc. to NAMUR NE 43	Individual upscale/downscale action for Sensor break, Sensor short-circuit, Sensor drift (only double RTD or T/C) and Low sensor isolation
Output control acc. to NAMUR NE 89	Individual upscale/downscale action for Maximum sensor wire resistance exceeded, (>50 ohm per wire for RTD and >10000 ohm loop resistance for T/C)
Status information via HART communication acc. to NAMUR NE 107 and via ConSoft	Sensor break, Sensor short-circuit, Sensor drift, Low sensor isolation and Sensor redundancy switchover (Sensor backup)

### General data

Line frequency rejection	Selectable 50 Hz, 60 Hz or 50/60 Hz
Isolation	1500 VAC, 1 min
Ex-approval	R520N ATEX: II 3 G Ex nL IIC T4-T6 In progress: FM, CSA, IECEx, GOST
	R520X/R520XS ATEX: II 2(1) G Ex ia IIC T4-T6 In progress: FM, CSA, IECEx, GOST
Power supply, polarity protected	R520/R520N/R520S 10 to 36 VDC, Standard power supply
	R520X/R520XS 10 to 30 VDC, I.S. power supply

### Environment conditions

Ambient temperature	Storage Operating	-40 to +85 $^{\circ}$ C -20 to +70 $^{\circ}$ C
Humidity		5 to 95 %RH
Vibration		Acc. to IEC 60068-2-6, test Fc, 10 to 2000 Hz, 10 g
Shock		Acc. to IEC-60068-2-31, test Ec
EMC	Standards	EN 61326-1:2006; EN 61326-3-1:2009, NAMUR NE 21
	Immunity performance	Criteria A, Surge test influence max. $\pm$ 0.5 % of span

### Housing

Mounting		Rail acc. to DIN EN 50022, 35 mm
Material		PC/ABS, RoHS compliant
Flammability acc. to UL		V0/HB
Connection	Single/stranded wires	Max. 1.5 mm <sup>2</sup> , AWG 16
Weight		70 g
Protection, housing / terminals		IP 20 / IP 00

### Accuracy and stability

Accuracy (reference 20 °C)	RTD and Thermocouple	See table below
	Resistance Digital accuracy <sup>1)</sup>	0-1000 Ω: Max of ±20 mΩ or ±0,020 % of MV 1000-4000 Ω: ±0,025 % of MV or max 0,5 Ω
Temperature influence	Resistance Analog accuracy <sup>1)</sup>	±0,03 % of span
	Voltage Digital accuracy <sup>1)</sup>	±5μV or ±0,010 % of MV
	Voltage Analog accuracy <sup>1)</sup>	±0,03 % of span
	RTD and Thermocouple	See table below
Cold Junction Compensation (CJC)	Resistance	±0.005 % of span per °C
	Voltage	±0.005 % of span per °C
		±0.5 °C within ambient temperature -40 to +85 °C
Sensor wire influence	RTD and Resistance, 2-wire	Adjustable wire resistance compensation
	RTD and Resistance, 3-wire	Negligible, with equal wire resistance
	RTD and Resistance, 4-wire	Negligible
	Thermocouple and Voltage	Negligible
Supply voltage influence	Within specified limits	<±0.001 % of span per V
Long-term drift		Max of ±0.01 °C or ±0.01 % of span per year

<sup>1)</sup> Total accuracy = Sum of digital and analog accuracy, calculated as an RMS (Root Mean Square) value

## Accuracy specifications and minimum spans for RTD and Thermocouples

### Conformance level 95 % (2σ)

Input type	Temperature range	Minimum span	Accuracy Maximum of:	Temperature Influence (Deviation from ref. temp. 20 °C)
RTD Pt100	-200 to +850 °C	10 °C	±0.1 °C or ±0.05 % of span	±0.005 % of span per °C
RTD PtX <sup>1)</sup>	Corresp. to max. 4 kΩ	10 °C	±0.1 °C or ±0.05 % of span	±0.005 % of span per °C
RTD Ni100	-60 to +250 °C	10 °C	±0.1 °C or ±0.05 % of span	±0.005 % of span per °C
RTD Ni 120	-60 to +250 °C	10 °C	±0.1 °C or ±0.05 % of span	±0.005 % of span per °C
RTD Ni 1000	-50 to + 180 °C	10 °C	±0.1 °C or ±0.05 % of span	±0.005 % of span per °C
RTD Cu10	-50 to +200 °C	83 °C	±1.5 °C or ±0.1 % of span	±0.01 % of span per °C
T/C type B	+400 to +1800 °C	700 °C	±1 °C or ±0.1 % of span <sup>2)</sup>	±0.005 % of span per °C
T/C type C	0 to +2315 °C	200 °C	±1 °C or ±0.1 % of span <sup>2)</sup>	±0.005 % of span per °C
T/C type D	0 to +2315 °C	200 °C	±1 °C or ±0.1 % of span <sup>2)</sup>	±0.005 % of span per °C
T/C type E	-200 to +1000 °C	50 °C	±0.25 °C or ±0.1 % of span <sup>2)</sup>	±0.005 % of span per °C
T/C type J	-200 to +1000 °C	50 °C	±0.25 °C or ±0.1 % of span <sup>2)</sup>	±0.005 % of span per °C
T/C type K	-200 to +1350 °C	50 °C	±0.25 °C or ±0.1 % of span <sup>2)</sup>	±0.005 % of span per °C
T/C type N	-100 to +1300 °C	100 °C	±0.25 °C or ±0.1 % of span <sup>2)</sup>	±0.005 % of span per °C
T/C type N	-250 to -100 °C	100 °C	±1 °C <sup>2)</sup>	±0.05 % of span per °C
T/C type R	-50 to +1750 °C	300 °C	±1 °C or ±0.1 % of span <sup>2)</sup>	±0.005 % of span per °C
T/C type S	-50 to +1750 °C	300 °C	±1 °C or ±0.1 % of span <sup>2)</sup>	±0.005 % of span per °C
T/C type T	-200 to +400 °C	50 °C	±0.25 °C or ±0.1 % of span <sup>2)</sup>	±0.005 % of span per °C

<sup>1)</sup> (10 ≤ X ≤ 1000)

<sup>2)</sup> CJC error is not included

## Input connections

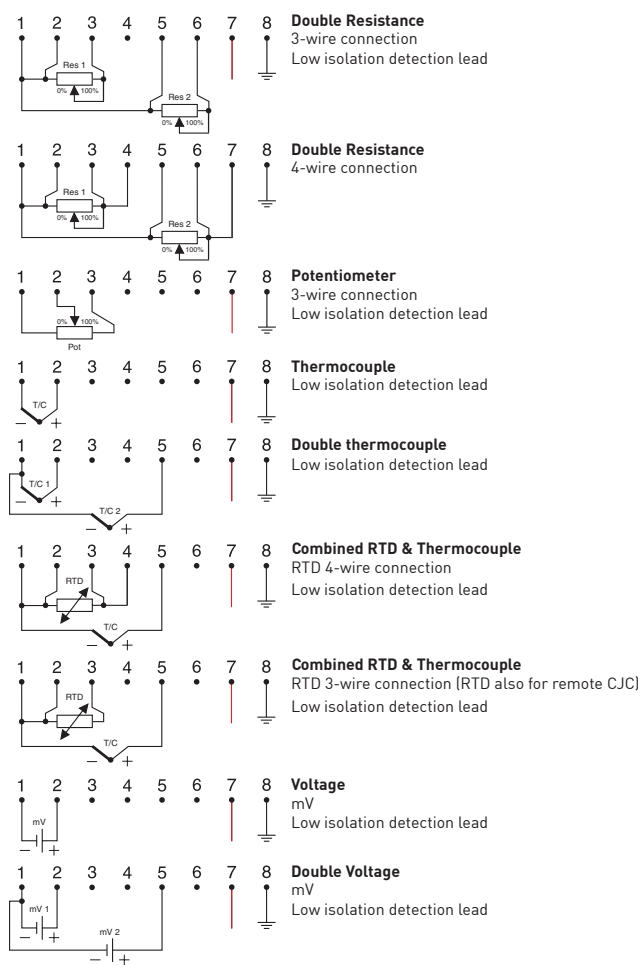
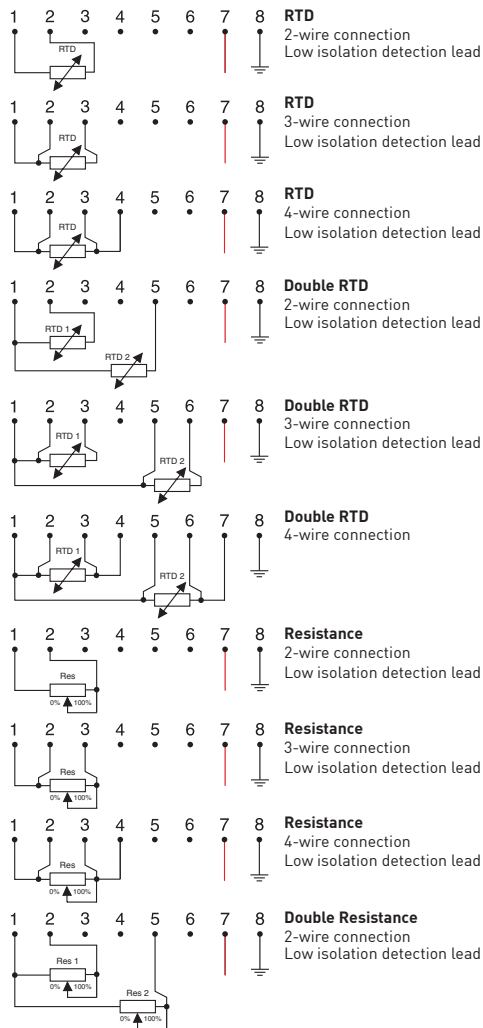

## Output connections

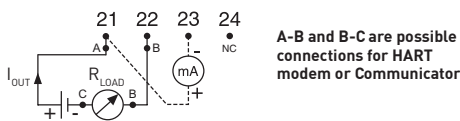

## Output load diagram

$$R_{LOAD}(\Omega) = (U-10)/0.022$$

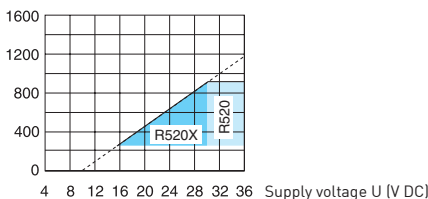

## Dimensions

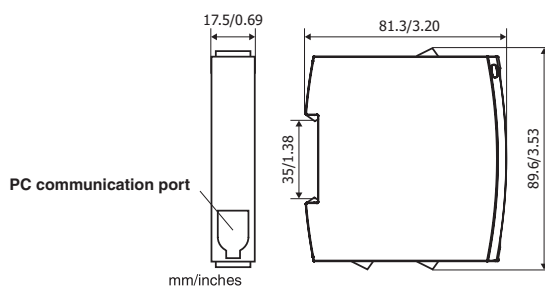

## Ordering information

R520	70R5200010
R520S, SIL 2 compatible	70R5200510
R520N	70R520N010
R520X	70R520X010
R520XS, SIL 2 compatible	70R520XS10
ICON PC configuration kit (USB-conn.)	70CFGUS001
Configuration	70CAL00001