

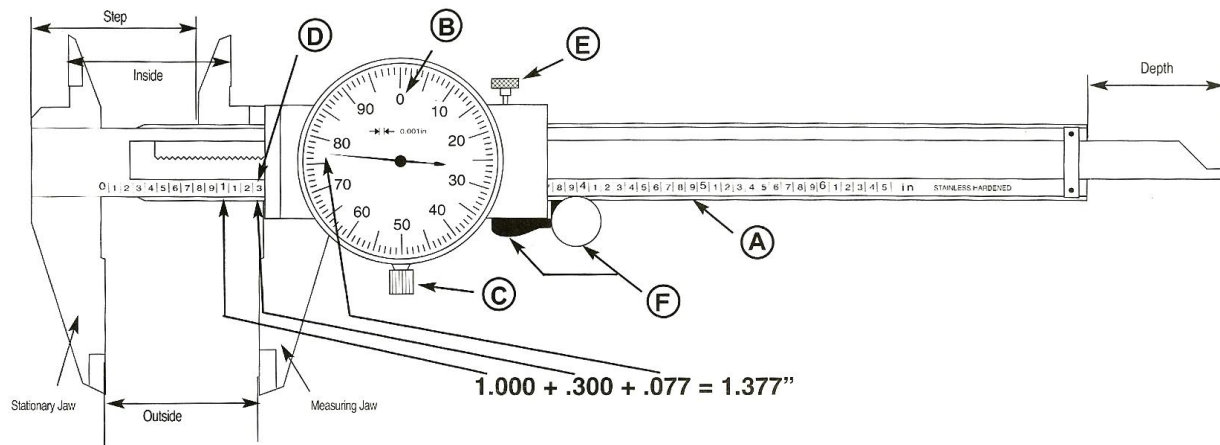

## No.107 Dial Calipers:



- A) The lower edge of the caliper beam is scaled in tenths of an inch, (.100), and measures up to 6 inches. Each full inch and incremental tenth of an inch is indicated.
- B) The dial face of the caliper is scaled in thousandths of an inch, (.001), and measures up to 100 thousandths, one full revolution. Every incremental ten thousandths of an inch, (.010), is indicated.
- C) The dial face bezel allows for adjustment to ZERO before taking measurements. Open and clean jaws. Completely close jaws. Slightly loosen thumb screw located at the bottom of the bezel. Rotate the bezel to align the indicator needle with ZERO and retighten thumb screw.
- D) Beam Reading Indicator
- E) Measuring Jaw Locking Screw
- F) Rolling thumb adjustment knob allows for precise, one-handed operation.

## INSTRUCTIONS for reading your No. 107 Precision Dial Caliper.

- A) The lower edge of the caliper beam is scaled in tenths of an inch, (.100), and measures up to 6 inches. Each full inch and incremental tenth of an inch is indicated.
- B) The dial face of the caliper is scaled in thousandths of an inch, (.001), and measures up to 100 thousandths, one full revolution. Every incremental ten thousandths of an inch, (.010), is indicated.
- C) The dial face bezel allows for adjustment to ZERO before taking measurements. Open and clean jaws. Completely close jaws. Slightly loosen thumb screw located at the bottom of of the bezel. Rotate the bezel to align the indicator needle with ZERO and retighten thumb screw.
- D) Beam Reading Indicator.
- E) Measuring Jaw Thumb Rest and Roller.  
**OPEN AND CLOSE WITH THUMB ROLLER ONLY. DO NOT FORCE.**
- F) Measuring Jaw Locking Screw.

EXAMPLE: Beam Reading 1" + .300" = 1.300"  
 Dial Reading .077"  
 Total Reading 1.377"

**WARNINGS: DO NOT APPLY OIL TO ANY PART OF THIS CALIPER. KEEP CALIPER CLEAN.**

## INSTRUCCIONES: para medir con el Calibrador de Precisión con Dial No. 107.

- A) La escala de la barra inferior esta dividida en décimos de pulgada (0,100), mide hasta 6 pulgadas e indica cada pulgada completa y cada incremento de un décimo de pulgada.
- B) La cara del dial del calibrador tiene una escala dividida en milésimas de pulgada (0,001), mide hasta 100 milésimas (una revolución completa) e indica cada incremento de diez milésimos de pulgada (0,010).
- C) El bisel del dial permite calibrar a CERO antes de tomar las medidas. Abrir las quijadas, limpiarlas y volverlas a cerrar completamente. Aflojar levemente el tornillo ubicado en la parte inferior del bisel. Girar el bisel hasta alinear la línea indicadora con el CERO y reajustar el tornillo.
- D) Indicador de medición de la barra .
- E) Apoyo y rodillo para el dedo en la quijada medidora.  
**ABRIR Y CERRAR CON EL DEDO, USANDO SÓLO EL RODILLO. NO FORZAR.**
- F) Tornillo de fijación de la quijada medidora.

Ejemplo: Lectura de la barra 1" + 0.300" = 1,300"  
 Lectura del dial 0,077"  
 Lectura total 1,377"

**ADVERTENCIA: NO APLICAR ACEITE A PARTE ALGUNA DE ESTE CALIBRADOR. MANTENERLO LIMPIO.**



**Avoid injury:**  
Always wear OSHA/ANSI approved eye protection (goggles, face shield) when using tools.

**Évitez les blessures :**  
Portez toujours une protection oculaire (lunettes ou masque facial) homologuée OSHA/ANSI quand vous utilisez des outils.

**Evite lesiones:**  
Siempre use protección ocular aprobada por OSHA/ANSI (gafas de seguridad, protector facial) cuando utilice herramientas.

## INSTRUCTIONS pour la lecture des relevés de votre compas à cadran de précision n° 107.

- A) La verge inférieure du compas est graduée en dixièmes de pouce (0,100) et peut mesurer jusqu'à 6 pouces. Chaque pouce complet et de pouce chaque dixième est indiqué.
- B) La face du cadran du compas est graduée en millièmes d'un pouce (0,001) et peut mesurer jusqu'à 100 millièmes – une révolution complète. Chaque dix millième d'un pouce (0,010) est indiqué.
- C) L'anneau d'encadrement de la face du cadran permet de régler l'appareil à ZÉRO avant de pendre les mesures. Ouvrez et nettoyez les mâchoires. Fermez complètement les mâchoires. Desserrez légèrement la vis située en bas de l'anneau d'encadrement. Tournez l'anneau d'encadrement pour aligner l'aiguille indicatrice avec le ZÉRO et resserrez ensuite la vis.
- D) Indicateur de relevé de la verge.
- E) Appui-pouce et rouleau de la mâchoire de mesure.  
**OUVREZ ET FERMEZ SEULEMENT AVEC LE ROULEAU. NE PAS LE FORCER.**
- F) Vis de blocage de la mâchoire de mesure.

EXEMPLE: Relevé de la verge 1" + 0,300" = 1,300"  
 Relevé du cadran 0,077"  
 Relevé total 1,377"

**AVERTISSEMENT: N'APPLIQUEZ JAMAIS DE L'HUILE À AUCUNE PARTIE DE CE COMPAS. GARDEZ LE COMPAS PROPRE.**

FRACTION - DECIMAL - METRIC EQUIVALENTS FRACIONS - DECIMALES - EQUIV. MÉTRIQUE FRACCIÓN - DECIAL - EQUIV. MÉTRICAS					
INCH/Po/Pulg.	DECIMAL	M/M	INCH/Po/Pulg.	DECIMAL	M/M
1/64	.0156	.397		.5118	13.000
	.0197	.500	33/64	.5156	13.097
1/32	.0313	.794	17/32	.5313	13.494
	.0394	1.000		.5315	13.500
3/64	.0469	1.191	35/64	.5469	13.891
	.0591	1.500		.5512	14.000
1/16	.0625	1.588	9/16	.5625	14.288
5/64	.0781	1.984		.5709	14.500
	.0787	2.000	37/64	.5781	14.684
3/32	.0938	2.381		.5906	15.000
	.0984	2.500	19/32	.5938	15.081
7/64	.1094	2.778	39/64	.6094	15.478
	.1181	3.000		.6102	15.500
1/8	.1250	3.175	5/8	.6250	15.875
	.1378	3.500		.6299	16.000
9/64	.1406	3.572	41/64	.6406	16.272
5/32	.1563	3.969		.6496	16.500
	.1575	4.000	21/32	.6563	16.669
11/64	.1719	4.366		.6693	17.000
	.1772	4.500	43/64	.6719	17.066
3/16	.1875	4.763	11/16	.6875	17.463
	.1969	5.000		.6890	17.500
13/64	.2031	5.159	45/64	.7031	17.859
	.2165	5.500		.7087	18.000
7/32	.2188	5.556	23/32	.7188	18.256
15/64	.2344	5.953		.7283	18.500
	.2362	6.000	47/64	.7344	18.653
1/4	.2500	6.350		.7480	19.000
	.2559	6.500	3/4	.7500	19.050
17/64	.2656	6.747	49/64	.7656	19.447
	.2756	7.000		.7677	19.500
9/32	.2183	7.144	25/32	.7813	19.844
	.2953	7.500		.7874	20.000
19/64	.2969	7.541	51/64	.7969	20.240
5/16	.3125	7.938		.8071	20.500
	.3150	8.000	13/16	.8125	20.638
21/64	.3281	8.334		.8268	21.000
	.3346	8.500	53/64	.8281	21.034
11/32	.3438	8.731	27/32	.8438	21.431
	.3543	9.000		.8465	21.500
23/64	.3594	9.128	55/64	.8594	21.828
	.3740	9.500		.8661	22.000
3/8	.3750	9.525	7/8	.8750	22.225
25/64	.3906	9.922		.8858	22.500
	.3937	10.000	57/64	.8906	22.622
13/32	.4063	10.319		.9055	23.000
	.4134	10.500	29/32	.9063	23.019
27/64	.4219	10.716	59/64	.9219	23.416
	.4331	11.000		.9252	23.500
7/16	.4375	11.112	15/16	.9375	23.813
	.4528	11.500		.9449	24.000
29/64	.4531	11.509	61/64	.9531	24.209
15/32	.4688	11.906		.9646	24.500
	.4724	12.000	31/32	.9688	24.606
31/64	.4844	12.303		.9843	25.000
	.4921	12.500	63/64	.9844	25.003
1/2	.5000	12.700	1	1.0000	25.400