

# PAPERLESS RECORDER

## DATA SHEET

PHF-2

This is a paperless recorder that displays measured data on the LCD in real time and stores data in CompactFlash.

The type of input such as thermocouple, resistance bulb, D.C. voltage (current), etc. can be arbitrarily set to 6 channels at the maximum.

The data stored in CompactFlash can be regenerated on the screen, and the use of supplied support software allows the data to be regenerated on a PC screen.

The data recorded in ASCII format can be directly read in a spreadsheet such as Excel, which facilitates the processing on a PC. (The data recorded in binary format cannot be read in.)



## FEATURES

1. **Large capacity storage by CompactFlash**  
Measured data is periodically stored in CompactFlash. Large storage capacity of up to 512MB allows display files for approximately 4 years to be recorded continuously at the display refresh cycle of 30 seconds (in the case of ASCII data format, 6 channels).
2. **Quick search and display of past data**  
Data stored in CompactFlash can be displayed in succession by scrolling the screen.
3. **Various display capability**  
Depending on the object of measurement, the most suitable display format can be selected from a variety of formats including bar graph display, trend display, digital display, etc.
4. **PC support software supplied as standard**  
Loader software that enables easy display and change of set data and data viewer software that regenerates the data stored in CompactFlash are supplied as standard.
5. **Compact size**  
160 (W) × 144 (H) × 185 (D) mm (Panel mounting), 1.5kg compact size
6. **6-point recording (Option)**  
12 types of thermocouples, 5 types of resistance bulbs and DC voltage/current input can be recorded up to 6 points.
7. **Screen saver function**  
If the non-operation exceeds the setting value of parameter, "LCD lights-out time", recorder turns off the backlight. Setting range of this parameter is 0 to 60 minutes. If the setting value is "0", this function doesn't work, so the backlight remains on during power on. Screen saver function makes the life of backlight expand and power consumption reduce.
8. **Ethernet function (Option)**  
FTP, Web server, e-mail and MODBUS-TCP are available using 10Base-T.

## SPECIFICATIONS

### Input system

- Number of input points:**  
3 points or 6 points (Can be selected at the time of purchase)
- Input circuit:** Input mutual isolation  
Resistance bulb measured current: about 1 mA
- Measuring cycles:**  
3 or 6 points....100ms cycles
- Recording cycle:** 1 sec to 12 hours
- Input types:** Thermocouple, resistance bulb, DC voltage, and DC current (Shunt resistors are fitted in input terminals).  
Note) Order a shunt resistor (type: PHZP0101) separately.

### Measuring range

Input types		Reference range
Thermocouple	B	400.0 to 1760.0°C
	R	0.0 to 1760.0°C
	S	0.0 to 1760.0°C
	K	-200.0 to 1370.0°C
	E	-200.0 to 800.0°C
	J	-200.0 to 1100.0°C
	T	-200.0 to 400.0°C
	N	0.0 to 1300.0°C
	W	0.0 to 1760.0°C
	L	-200.0 to 900.0°C
	U	-200.0 to 400.0°C
PN	0.0 to 1300.0°C	
Resistance bulb	JPt100	-200.0 to 600.0°C
	Pt100	-200.0 to 600.0°C
	Ni100	-60.0 to 180.0°C
	Pt50	-200.0 to 600.0°C
	Cu50	-50.0 to 200.0°C
DC voltage	50mV	0.00 to 50.00mV
	500mV	0.0 to 500.0mV
	1-5V	1.000 to 5.000V
	0-5V	0.000 to 5.000V

Note) B, R, S, K, E, J, T : JIS C 1602, DIN IEC 584-1  
 N : NICOSIL-NISIL (IEC 584)  
 W : 5%Re-26%Re · W (Hoskins Mfg. Co. USA)  
 L : Fe-Cu · Ni (DIN 43710)  
 U : Cu-Cu · Ni (DIN 43710)  
 PN : Platinum  
 JPt100 : JIS C 1604-1999 (Old JIS Pt 100)  
 Pt100, Pt50 : JIS C 1604, DIN IEC 751

**Selection of input types:**

By key operation on the front panel. Note that the same input type (thermocouple, resistance bulb, voltage) should be selected for channel 4 and 5. Refer to "Setting method of input types" for details.

**Burn-out function:**

Equipped in thermocouple and resistance bulb inputs as standard, and overswings the recording to 100% side.  
Thermocouple burn-out current:  
approx. 0.2  $\mu$ A

**Input filter function:**

Settable for each channel (primary delay filter) Time constants are settable in the range from 0 to 900 sec.

**Scaling function:**

Possible by DC voltage (current) input  
Scaling range: -32767 to 32767  
Decimal position: settable at any point  
Unit symbol: settable up to 7 digits and 125+12 types

**Subtraction function:**

Subtraction between each channel is allowed.

**Square rooter function:**

Square rooter can be performed against the input value per each channel.

**Indication system**

**Indicator:**

5.7" TFT color LCD (320  $\times$  240 dots) with backlight, no contrast adjustment. On the LCD, certain picture elements remain lit or extinguished. On account of the nature inherent to LCD, the brightness may be non-uniform. But, such are not troubles.

**Color of indication:**

14 colors

**Applicable language:**

English, French, German, Italian (switchable)

**Life of backlight:** 50,000 hours (20°C)

(the complete indicator unit should be replaced when replacing backlight).

**Trend display:**

Direction: vertical and horizontal  
Number of channels: 6 channels or 4 channels or 3 channels for the screen (Input: 6 points at the maximum).  
Display refreshment cycles:  
select from 1 second to 12 hours  
No numerical value display. Scale display/no-display can be selected.

**Bar graph display:**

Direction: vertical  
Number of channels: 6 channels or 4 channels or 3 channels for the screen (Input: 6 points at the maximum).  
Display refreshment cycles: 1 second.

**Digital display:**

Number of channels: 6 channels or 4 channels or for the screen (Input: 6 points at the maximum).  
Display refreshment cycles: 1 second.

**Event summary display:**

Alarm summary and message summary can be displayed.

**Ethernet log display:**

E-mail sending, FTP server log in/off and MODBUS TCP/IP communication start/stop can be displayed.

**Parameter display/set:**

Already-set Data Display and Set Change Display screen

**TAG indication:**

Number. of characters to be displayed:  
Up to 8 characters at 6 channels on one screen or up to 16 (= 8  $\times$  2) characters at 4 channels on one screen.  
Characters to be displayed:  
Alphanumerical characters  
Tag, unit and channel number display:  
It depends on the screen. See below table.

Screen	Number of channel on one screen	Items			
		TAG1	TAG2	unit	ch number
Trend	4 or less	+	+	+	+
	more than 5	x		x	x
Bar graph	4 or less	+	+	+	+
	more than 5	x		x	x
Digital		all items are displayed			

x: only 1 item can be displayed.  
+: only 2 items can be displayed.

**Historical trend display:**

The past data can be displayed from the Compact Flash or internal memory. The past data file can be read and displayed with scroll display function or jump the cursor to the position which you entered date and time. Scale display/no-display can be selected.

**Number of screen groups:**

1 group (Up to 6 channels per 1 group can be registered.)

**Keyboard**

**No. of Keys:**

8

**Function:**

Use to select various screens and set various parameters.

**Recording function**

**External memory media:**

Compact Flash card  
(Format as FAT32, FAT16 or FAT, or recorder can't read and write.)

**Recording capacity:**

2GB maximum (compact flash). Limiting the recording file to 64MB is recommended (for 112 hours if display refresh cycle is 1 second. See Table 1 (p. 6).)  
(When the size of the recording file comes to be 256MB or more, a new file is created automatically and recording is maintained.)  
\* Please change the compact flash every six month to prevent the data losing.

**Recording method:**

Turning ON the REC key allows measured data to be written at fixed cycles.  
Recorded as a new file whenever the recording starts

**Data save cycles:**

Linked to the display refreshment cycles on the "Trend display" screen. However, they are automatically set to about 1 minute if the refreshment cycles are set to less than 1 minute.

**Trend data:**

Average, instance or min. and max. measured values out of measured data that are sampled at the measuring cycles are saved.

**Event data:**

Saves alarm data and power ON data when the power turns off and on during recording.

**Storage capacity:**

Approximately 4 years when the display refresh cycle is 30 seconds (in the case of 6-channel recording in ASCII data format, and 512MB Compact Flash is used). Refer to Table 1.

**Memory usage:**

Indicates the memory which has already used on the screen. When all the memory is used up, you can stop recording or delete the oldest recording file to save the newest data.

**Compact flash card form:** PHZP2801**(CF card)**

(If a card other than the above is used, no operation assurance is ensured.

Meanwhile, as for other CF cards for which operation check will have been completed, the results will be posted on our company's homepage sequentially. Please refer to this website.)

**Data format:**

Either of ASCII or binary format can be selected. (Switching cannot be made while the recording is in progress. In the case of ASCII format, the data can be directly read on Excel, etc.)

Note: The data recorded in binary format cannot be read directly.

Approximately 118 bytes per sample (for 6-channel input in ASCII format) or approximately 28 bytes (for 6-channel input in binary format)

**Alarm function****No. of settings:**

Up to 4 alarms for each channel are settable.

**Type of alarm:**

High/Low limits

**Indication:**

Status (alarm types) is displayed on digital display unit when an alarm occurs.

History display on alarm summary (Alarm start/cancel time and alarm types)

**Hysteresis:**

Set within the recording range of 0 to 100% (it is effective only in case of high/low limit alarm)

**Relay output:**

Number of points; 10

**Alarm latch function:**

Keeps alarm indication and alarm output turning on after alarm reset.

ON/OFF operation is performed according to key setting.

**Power supply****Rated power voltage:**

100 to 240V AC

**Range of operating voltage:**

90 to 264V AC

**Supply frequency:**

50/60Hz (both employable)

**Power consumption**

100V AC	About 32VA
240V AC	About 42VA

**Structure****Mounting method:**

Panel-mounted (vertical panel)

**Thickness of panel:**

2 to 26 mm

**Materials:**

PC-ABS for case and bezel

**Color:**

Black

**External dimensions:**

Panel-mounted: 160 (W) × 144 (H) × 185 (D) mm

**Mass:**

Approx. 1.5 kg (no option)

**External terminal board:**

Screw terminals (M3 thread)

RJ45 : Ethernet terminal (option)

**Normal operating condition****Power voltage:** 90 to 264V AC**Supply frequency:**

50/60 Hz ±2% (both employable)

**Ambient temperature:** Panel-mounted

0 to 50°C

(without Ethernet option\*1)

0 to 40°C

(with Ethernet option\*2)

Note) In case of 30°C or more of ambient temperature, this display might be fogged little bit (This is not out of order).

**Ambient humidity:**

20 to 80%RH

**Vibration:**

10 to 60Hz 0.2m/s<sup>2</sup> or less

**Shock:**

None

**Magnetic field:**

400 A/m or less

**Signal source resistance:**

Thermocouple input .... 1kΩ or less

Resistance bulb input... 10Ω/wire or less (resistance of each wire of 3-wire system should be balanced).

Voltage input... 0.1% or less of input resistance

**Mounting posture:**

Forward tilt 0°, backward tilt within 30°, horizontal 0°

**Warm-up time:** One hour or more after power ON**Environmental protection:**

IEC IP50 (Front)/20 (Terminal)

**Installation category:**

II

**Pollution degree:** 2**Operating altitude:**

2000m max.

\*1: In case of the 12th digit of ordering code is "Y"

\*2: In case of the 12th digit of ordering code is "E"

**Safety and EMC standard**

Safety standard: Based on IEC61010-1  
 EMC standard: Based on EN61326

**Transportation/storage conditions**

Temperature: -10 to +60°C  
 Humidity: 5 to 90%RH, no condensation  
 Vibration: 10 to 60Hz, 2.45m/s<sup>2</sup> or lower  
 Shock: 294m/s<sup>2</sup> or lower (packed state)

**Reference standard**

Accuracy/resolution:  
 Measuring conditions (23±2°C, 65±10% RH, power voltage, frequency fluctuation within ±1%, no external noise, warm-up time of 1 hour or more, vertical mounting, standard values of signal source resistance and wiring resistance... within 1% )

Input types	Digital indication accuracy	Note 1	Digital indication resolution
Thermocouple	B R S K E	± (0.15%+1 digit)	0.1°C
	J T N W L U PN	±(0.3%+1 digit) for the range shown below Thermocouple B : 400 to 600°C Thermocouples R and S : 0 to 300C Thermocouples K, E, J, T, L and U : -200 to -100°C	
Resistance bulb	JPt100 Pt100 Pt50	± (0.15%+1 digit)	0.1°C
	Ni100 Cu50	± (0.5%+1 digit)	
DC voltage	50mV 500mV 1-5V 0-5V	± (0.15%+1 digit)	10µV
			100µV
			1mV
			1mV

Note 1) Digital indication accuracy is a percentage (%) of the value in the measuring range on page 1.  
 Note 2) No error of reference contact compensation of thermocouple is included.

**Error of reference contact compensation:**  
 K, E, J, T, N, L, U, PN: ±0.5°C  
 R, S, B, W: ±1.0°C  
 (when measured at 0°C or more)

**Max. input voltage:**  
 Thermocouple, resistance bulb, DC voltage: ±10V DC (continuous)

**Input resistance:** Thermocouple, DC voltage:  
 About 1MΩ

**Others**

**Clock:** With calendar function (Christian era)  
 Accuracy: ±100ppm or less (monthly error: about 4 minutes)  
 However, time error at ambient temperature 23±2°C and power ON/OFF is not included.

**Memory backup:** Parameters are saved to the internal non-volatile flash memory.  
 The clock and totalized data are backed up with built-in lithium battery.

**Insulation resistance:**  
 100 MΩ or more (when measured between each terminal and ground by using a 500V DC megger)

**Withstand voltage:**  
 Power terminal – ground: 2000V AC, 1 min  
 Input terminal – ground: 500V AC, 1 min  
 Alarm terminal – ground: 2000V AC, 1 min  
 Alarm terminal – alarm terminal:  
 750V AC, 1 min  
 Communication terminal – ground:  
 500V AC, 1 min

**Effect on operation**

**Effect of power supply fluctuation conditions:**  
 For the fluctuation in the range from 90 to 264V AC (frequency: 50/60Hz)  
 Reading change (100V AC base): ±(0.2%+1 digit) or lower.  
 For the fluctuation in the range from 47 to 63Hz (power voltage: 100V AC)  
 Reading change (50Hz base): ±(0.2%+1 digit) or lower.

**Effect of input signal resistance:**  
 Thermocouple input: (0.5µV/Ω)+1 digit or less  
 DC voltage: Fluctuation for resistance value equivalent to 0.1% of the input resistance: ±(0.2%+1 digit) or lower.  
 Resistance bulb (for wiring resistance of 10Ω for 1 line (the same for 3 lines))  
 Reading change: ±(0.2%+1 digit) or lower.

**Effect of ambient temperature:**  
 Reading change: ±(0.3%+1 digit)/10°C or lower.

**Effect of Mounting position:**  
 For the backward 30° slant  
 Reading change: ±(0.2%+1 digit) or lower.

**Effect of vibration:**  
 When sine wave of 10 to 60Hz with the acceleration of 0.2m/s<sup>2</sup> is applied in each direction for 2 hours.  
 Reading change: ±(0.2%+1 digit) or lower.

**Effect of external noise:**  
 Normal mode noise (50, 60Hz±0.1Hz)  
 ...20dB or more  
 Common mode noise (50, 60Hz±0.1Hz)  
 ...120dB or more  
 (Thermocouple input: minus terminal-ground)  
 (Resistance bulb input: b Line-ground)

**Additional function (option)**

■ Alarm relay output/DI (11th digit of code symbols: "1")  
 A card with 10-point relay output and 5-point DI input can be mounted.  
**Terminal structure:**  
 M3 screw terminal

**Alarm relay output:**  
 Contact output (SPST:10 points),  
 Individual channel or common output (OR output) allowed.  
 DO1: Contact capacity; 150V/3A AC, 30V/3A DC (resistive load)  
 DO2-10: Contact capacity; 240/3A AC, 30V/3A DC (resistive load)

**DI input:** No-voltage contact input (5 points)  
 The following control is allowed by contact input.  
 (1) Recording start/stop  
 (2) LCD turns on  
 (3) E-mail sending  
 On pulse width: 200msec or longer  
 Off pulse width: 200msec or longer

### Ethernet (Option)

The following can be performed through the Ethernet function.

■ **HTTP server (Internet Explorer 6 is compatible)** Note 1  
**Measurement display:**

Digitally displays the measurement of each channel of the recorder and alarm occurrence status.

**Event summary display:**

Displays event summary including alarm ON/OFF.

**Main unit information display:**

Displays memory use conditions and information on the main unit such as the battery end warning.

**Integrated value display:**

Digitally displays the integrated value of each channel of the recorder.

■ **FTP server (Internet Explorer 6 is compatible.)** Note 1

**File download:** Record files stored in compact flash (CF) can be downloaded from the browser.

**File delete:** Record files stored in CF can be deleted from the browser.

**Access authentication:**

Authenticates access authority to FTP server.

■ **SMTP (e-mail client)**

Transmits e-mails to specified address under the following conditions.

- (1) When an alarm turns on or off
- (2) When DI is set to ON or OFF
- (3) When an error occurs to the main unit (such as low battery or no memory space)
- (4) At specified intervals

■ **MODBUS TC/IP**

**Data read:** Settings can be read through MODBUS TCP/IP communication.

**Data write:** Settings can be written through MODBUS TCP/IP communication.

Note1: Neither Netscape nor Mozilla Firefox is available.

### Support software

The following software is provided as standard.

- PC/AT-compatible machine
- Operation on PC98-series machines by NEC is not guaranteed.
- Operation on self-made or shop-brand PCs is not guaranteed.

■ **Loader software for PC**

**Major function:** Performs various parameter setting/change of the main unit

**O/S:** Windows 2000/XP, Windows 7 (Home Premium, Professional (Not applicable for 64 bit version))

**Required memory:**

64MB or larger

**Disk drive:** Windows 2000/XP/7-capable CD-ROM drive

**Hard disk capacity:**

Free capacity of 30MB or larger required

**Printer:** Windows 2000/XP/7-capable printer and printer driver

Note) PC loader communication cable (type PHZP1801) is separately required.

■ **Data viewer software**

**Major function:** Regenerates the past trend record on the PC from the data in the Compact Flash. Provided with historical trend display and event display functions.

**O/S:** Windows 2000/XP, Windows 7 (Home Premium, Professional)

**Required memory:**

64MB or larger

**Disk drive:** Windows 2000/XP/7-complaint CD-ROM drive

**Hard disk drive:** Free capacity of 30MB or larger required

**Printer:** Windows 2000/XP/7-capable printer and printer driver

### Standard functions

Function	Description
Record range voluntary setting	Recording range can be set by channel.
Input type setting	Input can be set by channel. (Key operation on the front face) The same input type is selected for channel 4 and 5. See "SELECTING INPUT TYPE" on the last page.
Skip function	Skips arbitrary channel display/recording.
Trend display	Time display: Time is displayed at the top of the trend display screen. Alarm display: On occurrence of an alarm and the restoration, alarm is displayed in the alarm display field. The Compact Flash usage is displayed at the top of the bargraph.
TAG name display	By channel, Maximum of 8 characters.
Screen name display	Displays the screen name (maximum of 16 characters).
Unit creation	Industrial units can be arbitrarily created, Maximum of 7 digits, 12 types.
Scaling function	Arbitrary scaling is allowed in the case of DC voltage input. Decimal point position can also be arbitrarily set in the range from -32767 to 32767.
PV shift	Shift the zero point and slant of the reading.
Input filter	Prevents sudden fluctuation of input for each channel (primary delay filter). Time constant: 0 to 900 seconds.
Burnout function	Displays the break of thermocouple/resistance bulb input by scaling out to 100% side.
Historical trend display	Regenerates and displays the data stored in the compact flash by scrolling the screen or jump to time when you entered.

**Table 1. Recording capacity**

Input point: 6

Data format: ASCII

The recording can be made for the period of time listed in the tables shown below. When the number of input points is 3, the period is approximately 1.6 times of those listed in the table.

In binary format, the period is approximately 4 times as long as those listed in the table.

CompactFlash size	256MB			
	1 sec	10 sec	30 sec	1 min
Recordable capacity(about)	26 days	265 days	2.1 years	4.3 years

When Compact Flash is not used, up to 600K bytes of the recording data and the event data can be stored in the main unit. (In case of 6-channel in Max./Min. recording, approximately 21,000 data can be stored. For 5 hour at the display refresh cycle of 1 second. The number of the save data varies depending on the number of the event data.

## ORDERING CODE

Digit	Specifications	Note
4	<Number of input points> 3 6	
11	<Alarm (relay) output/DI input> Without With	
12	<Communication> Without any communication With Ethernet communication	

PHF 

4	5	6	7	8	9	10	11	12	13
	1	B	1	2	-	E	1		V

↓  
5  
6

↓  
0  
1

↓  
Y  
E

## STANDARD ACCESSORY

Item	Quantity
	Panel mounting
Recorder (PHF)	1
Panel mounting bracket	2
CD-ROM   PC support software instruction manual	1
Noise filter for the power supply	1

## OPTIONAL ITEMS

Item	Code	Specification
Shunt resistor for DC current input	PHZP0101	10Ω ±0.1%
PC loader communication cable	PHZP1801	With USB-A and USB miniB * 3m
CD-ROM with Instruction manual and 2 support software	PHZP2101	
PC card adapter	PHZP0501	For Compact Flash
Compact Flash	PHZP2801-512 PHZP2801-01G	512MB 1GB

\* Shape of this cable is shown below

USB (A) Plug – USB (Mini-B) Plug

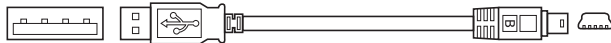

# OUTLINE DIAGRAMS (Unit : mm)

## PANEL MOUNTING

In the case of 3, 6-point input

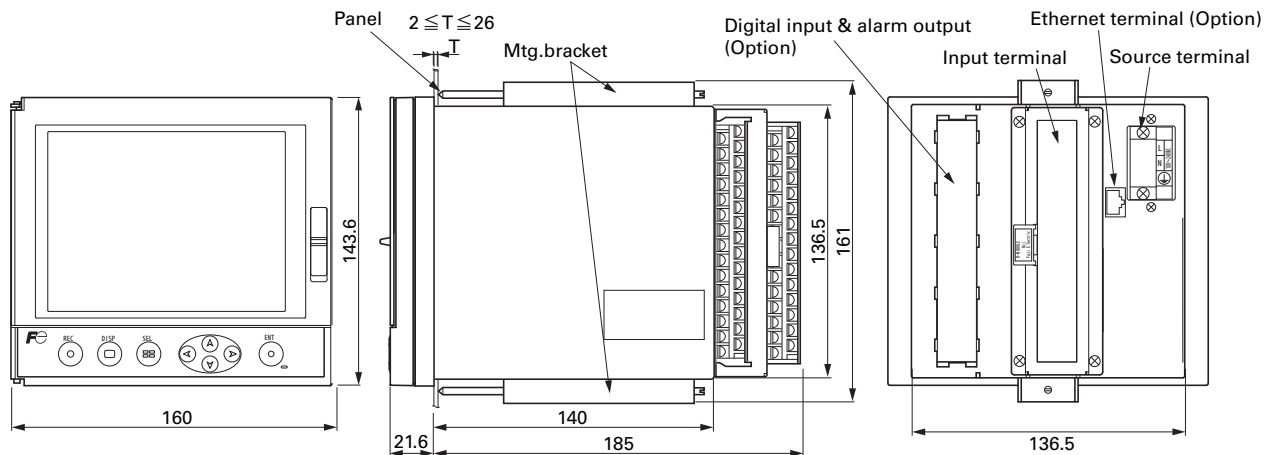

In the case of 3,6-point input

(Note) When placing the main unit on another instrument or on the floor, allow a space of 100mm or more between the unit and instrument or the floor.

## PANEL CUTOUT

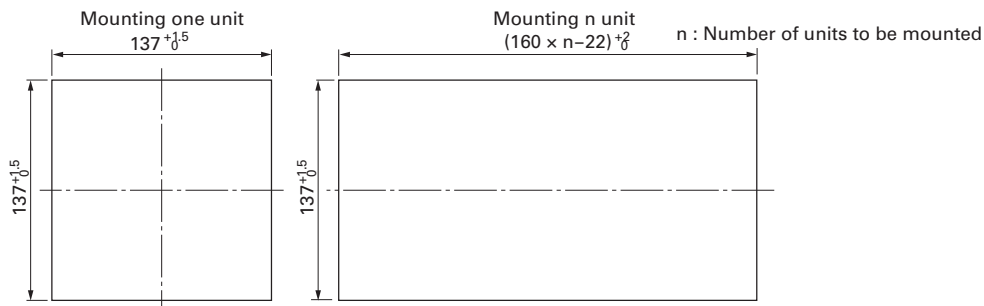

Do not use the water proof packing in case of mounting n unit

## EXTERNAL CONNECTION DIAGRAMS (M3 screw)

In the case of 3, 6-point input

Alarm (relay) output / digital Input terminal

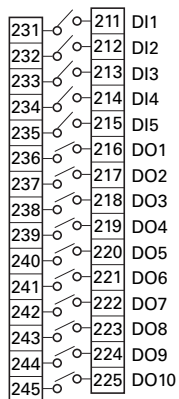

Input terminal

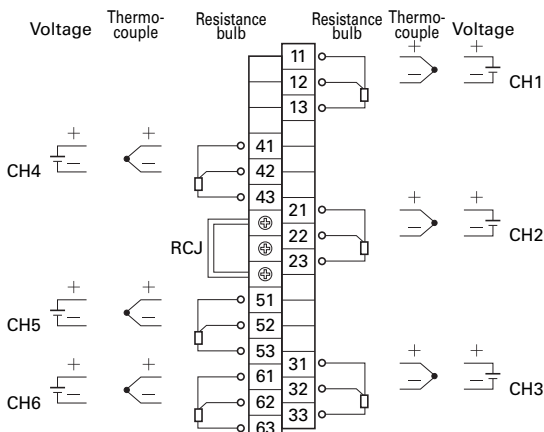

Source terminal

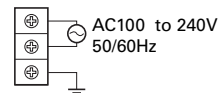

(Note1) For current input, connect an optional shunt resistance to a voltage input terminal.  
 (Note2) Do not use any input terminal which is not needed.

## SELECTING INPUT TYPE

The input types of channel 4 and 5 is the same.

Channel 5 can only be allocated the input type that is the same as channel 4.

The following input types are available.

Input category	Details
Thermocouple, 50mV	K, E, J, T, R, S, B, N, W, L, U, and PN thermocouples, 50mV
Resistance bulb	Pt100, JPt100, Ni100, Pt50, Cu50
500mV	500mV
5V	1 to 5V, 0 to 5V

Note) Arbitrary input type can be selected for any channels other than channel 4 and 5 irrespective of the type allocated to other channels.

### Example of channel input type selection

	Input type	Input category	Description
Channel 1	K thermocouple	Thermocouple, 50mV	
Channel 2	1-5V	5V	
Channel 3	500mV	500mV	
Channel 4	K thermocouple	Thermocouple, 50mV	The input type of the thermocouple and 50mV is the same.
Channel 5	50mV		
Channel 6	Pt100	Resistance bulb	

Note 1) Windows 2000/XP, Excel and Internet Explorer are the registered trademarks of Microsoft Corporation in the U.S.A.

Note 2) Compact Flash is the registered trademark of Sandisk Corporation.

Note 3) Modbus® is the trade mark or registered trade mark of AEG Schneider Automation International.

Note 4) PC98 series are the trade mark or registered trade mark of NEC Corp.

Note 5) Netscape is the trade mark or registered trade mark of Netscape Communication Corp.

Note 6) Mozilla Firefox is the registered trade mark of Mozilla Foundation.

### ⚠ Caution on Safety

\*Before using this product, be sure to read its instruction manual.

 **Fuji Electric Co., Ltd.**

Contact:  
Industrial Process Measurement, Inc.  
3910 Park Avenue, Unit 7  
Edison, NJ 08820  
732-632-6400  
support@instrumentation2000.com  
http://www.instrumentation2000.com