

Mini Hygro Thermo-Anemometer

Introduction

Congratulations on your purchase of Extech's Model 45158 Anemometer. The dual display indicates Air Velocity and Humidity, Dew Point, Ambient Temperature, or Temperature with wind-chill factor. With careful use, this meter will provide years of reliable service.

Operation

Turning the meter ON and OFF

- Press the ON/OFF/HOLD button to turn the meter ON
- Press and hold the ON/OFF/HOLD buttons for approx. 3 seconds to turn it OFF
- The meter's Auto Power OFF feature turns the meter OFF after 20 minutes of inactivity

Change the lower display parameter

- With the meter ON, press and hold down the ON/OFF/HOLD button
- While continuing to hold the ON/OFF/HOLD button, press the UNITS/MODE button repeatedly to step through Temperature (oF/oC), Humidity (RH%), Dew Point (TD), & Temperature with wind-chill factor (WCI). Note that the center display is Air Velocity.

Change the Air Velocity unit of measure

- Turn the meter OFF. Press and hold down both buttons until the display turns on and begins blinking then release both buttons
- Press the UNITS/MODE button repeatedly to step through the units (see specs for list)
- After 5 seconds the meter switches back to normal operation mode automatically

Select temperature units (oC or oF)

- Turn the meter OFF first. Press and hold down both buttons until the display turns on and begins blinking then release the buttons
- Press both buttons momentarily to change temperature units
- After 5 seconds the meter switches back to normal operation mode automatically

Taking Measurements

- Position the meter so that the airflow enters the meter vane from the rear of the meter (opposite side of front panel logo). A tripod mount is located on the bottom of the meter.

Max Hold

- Max Hold represents the highest measurement taken since the meter was turned on
- Press the UNITS/MODE button to display the Max reading (MAX icon appears)
- Press the UNITS/MODE button repeatedly to step through to the normal operating mode

Average mode

- 5 or 10 reading averages can be displayed in the Average Mode.
- Press UNITS/MODE 3 times for 5 reading averaging or 4 times for 10 readings
- To exit this mode, press the UNITS/MODE button until the icons on the left disappear

Data Hold

- Data Hold freezes the most recent displayed reading
- Press and hold the ON/OFF/HOLD button to activate Data Hold
- As long as the ON/OFF/HOLD button is held the reading will remain on the LCD

Copyright © 2013 FLIR Systems, Inc.

All rights reserved including the right of reproduction in whole or in part in any form

ISO-9001 Certified
www.extech.com

45158-EU-EN V3.4 8/13

Meter Description

- 1 Vane impeller
- 2 Impeller set screw (on rear of meter)
- 3 Relative Humidity sensor
- 4 Temperature sensor
- 5 LCD display
- 6 ON/OFF, HOLD key
- 7 UNITS, MODE key
- 8 Battery compartment (on rear)
- 9 Tripod mounting hole
- 10 Lanyard (neckstrap)

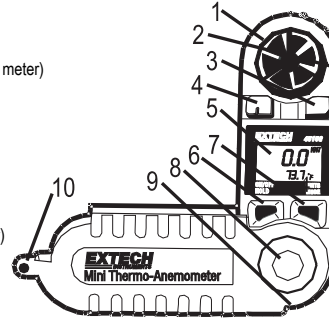

Specifications

Measurement	Range	Resolution	Accuracy (% of reading)
MPH (Miles per hour)	1.1 to 62.5 MPH	0.2 MPH	± (3% + 0.4 mph)
km/hr (kilometers per hour)	1.8 to 100.6 km/hr	0.7 km/hr	± (3% + 1.4 km/hr)
Knots (nautical miles per hour)	1.0 to 54.3 knots	0.3 knots	± (3% + 0.6 knots)
m/sec (meters per second)	0.5 to 28.0 m/s	0.1 m/s	± (3% + 0.2 m/s)
ft/min (feet per minute)	100 to 5500 ft/min	20ft/min	± (3% + 40 ft/min)
Beaufort force	1 to 17 BF	1 BF	± 1
Temperature	-18 to 50°C (0 to 122°F)	0.1°F/C	± 1.8°F (± 1°C)
Relative Humidity	10 to 95%	1%	± 5% RH
Dew Point	0 to 50°C (32 to 122 °F)	0.1°F/C	± 3.6°F (2°C)

General Specifications

Display	Dual LCD with low battery and multifunction indicators
Sensors	Sapphire bearing, non-corrosive vane for air velocity; Precision thermistor for temperature measurements
Average Mode	Choice of 5 or 10 reading averaging (2 second factory default)
Max and Data Hold Displays	Max recalls the highest reading; Data Hold freezes the display
Sample time	1 reading per second for air velocity and temperature (1 reading per 15 seconds for humidity with 2 second updates)
Water-resistant	To 1m(3')
Operating conditions	-15 to 50°C (5 to 122°F) / < 80% RH
Power supply	Lithium battery (CR-2032 or equivalent) / 400 hour battery life
Dimensions / Weight	Instrument: 133 x 70 x 19mm (5.25 x 2.75 x 0.75") Vane: 24mm (1") diameter /95 g (3 oz)

Maintenance

Battery Replacement

The 45158 has a low battery indicator (battery symbol). **Important: Turn the meter off before opening the battery compartment.** Using a coin, turn the battery compartment cover CLOCKWISE to remove it. Once opened, observe the position of the battery, placing the new one in the same position. Secure the battery compartment cover and dispose of the lithium battery in accordance with local, state, or national disposal codes.



All EU users are legally bound by the Battery Ordinance to return all used batteries to community collection points or wherever batteries / accumulators are sold. Disposal in household trash or refuse is prohibited.

Disposal: Follow the valid legal stipulations in respect of the disposal of the device at the end of its lifecycle

Other Battery Safety Reminders

- Never dispose of batteries in a fire. Batteries may explode or leak.
- Never mix battery types. Always install new batteries of the same type.

Impeller Replacement

- Remove the set screw next to the impeller assembly (on the rear of the meter).
- Twist the impeller assembly counter-clockwise to the OPEN position and remove it.
- Install impeller by inserting & twisting the new impeller assembly clockwise
- Tighten the set screw.

CFM Measurements

Measure the area of the duct using the diagrams below for rectangular and circular ducts (If the duct measurements are made in inches, divide the inches by 144 to get the area in square feet). Plug the area value (in square feet) in the cubic equations below. Note that the air velocity must be plugged into the cubic equations also.

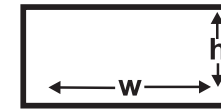

$$A = w * h$$

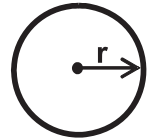

$$A = \pi r^2$$

$$\text{CFM (ft}^3/\text{min)} = \text{Air Velocity (ft/min)} \times \text{Area (ft}^2\text{)}$$

$$\text{CMM (m}^3/\text{min)} = \text{Air Velocity (m/sec)} \times \text{Area (m}^2\text{)} \times 60$$