

User Manual



Infrared Thermometer with 10:1 Distance-to-Sight Ratio

with NIST-Traceable Calibration

Model 20250-04

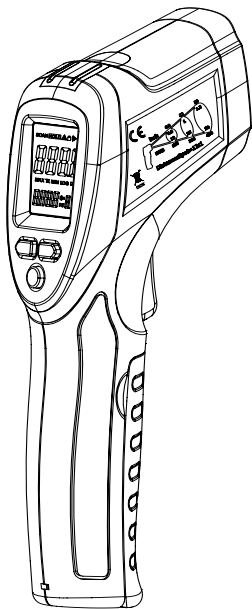

THE STANDARD IN PRECISION MEASUREMENT

Introduction

The Digi-Sense Infrared Thermometer (Model 20250-04) with 10 to 1 distance-to-sight ratio offers fast response and high accuracy. Advanced features include data Hold, Max/Min readings, and auto power-off. The instrument is fully tested and calibrated to NIST-traceable standards. Careful use of this meter will provide years of reliable service.

Unpacking

Check individual parts against the list of items below. If anything is missing or damaged, please contact your instrument supplier immediately.

1. Meter
2. One 9 V battery
3. User manual
4. NIST-traceable calibration report with data

Key Features

- 10:1 Distance-to-sight ratio
- 2.5% basic accuracy
- Fixed emissivity (0.95)
- Precise noncontact measurements
- Laser sighting
- User-selectable °C or °F units
- Automatic data Hold
- MAX/MIN temperature displays
- Automatic selection range and display resolution
- Trigger lock
- Backlight LCD
- Automatic power-off to conserve battery life

Meter Description

1. IR sensor
2. Laser pointer beam
3. LCD
4. °C/°F button
5. **MAX/MIN** button
6. **Laser / Backlight** button
7. Measurement trigger
8. Battery cover
9. Handle grip

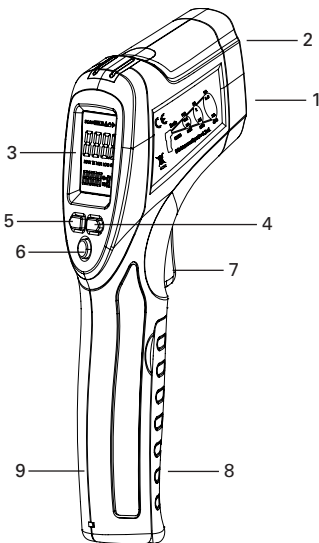

Display Layout

1. Fixed emissivity (0.95) scan icon
2. Temperature readout
3. Max and Min reading icons
4. SCAN measuring indicator
5. Data Hold icon
6. Laser point indicator
7. Low-battery indicator
8. °C or °F temperature units

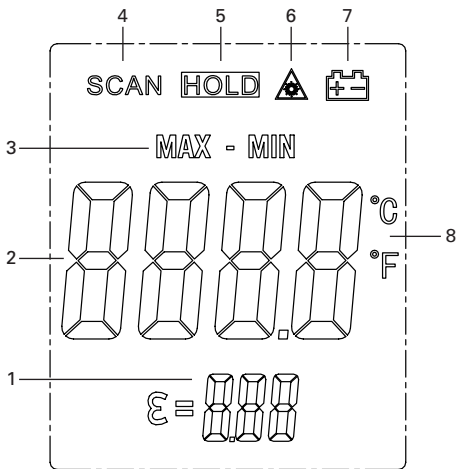

How it Works

Infrared thermometers measure the surface temperature of an object. The unit's optics sense emitted, reflected, and transmitted energy, which is collected and focused onto a detector. The unit's electronics translate the information into a temperature reading which is displayed on the unit. The laser is used for aiming purposes only.

Field of View

Make sure that the target is larger than the unit's spot size. The smaller the target, the closer you should be to it. When accuracy is critical, make sure the target is at least twice as large as the spot size.

Distance and Spot Size

As the distance (D) from the object increases, the spot size (S) of the area measured by the unit becomes larger.

Locating a Hot Spot

To find a hot spot, aim the thermometer outside the area of interest, then scan across with an up-and-down motion until you locate hot spot.

Emissivity

Emissivity is a term used to describe the energy-emitting characteristics of materials. Most (90% of typical applications) organic materials and painted or oxidized surfaces have an emissivity of 0.95 (fixed in the unit). Inaccurate readings will result from measuring shiny or polished metal surfaces. To compensate, cover the surface to be measured with black tape or flat black paint. Allow time for the tape to reach the same temperature as the material underneath it. Measure the temperature of the tape or painted surface. (Refer to table on page 8.)

Good Measuring Practices

Holding the meter by its handle, point the IR sensor toward the object whose temperature is to be measured. The meter automatically compensates for temperature deviations from ambient temperature. Keep in mind that it will take up to 30 minutes for the IR sensor to stabilize if going from ambient temperatures to a much higher (or lower) temperature measurement.

Reminders

- The unit is not recommended for measuring shiny or polished metal surfaces (stainless steel, aluminum, etc.). See **Emissivity** above.
- The unit cannot measure through transparent surfaces such as glass. It will measure the surface temperature of the glass instead.
- Steam, dust, smoke, etc. can prevent accurate measurement by obstructing the unit's optics.

Emissivity Values

Substance	Thermal emissivity	Substance	Thermal emissivity
Asphalt	0.90 to 0.98	Cloth (black)	0.98
Concrete	0.94	Human skin	0.98
Cement	0.96	Lather	0.75 to 0.80
Sand	0.90	Charcoal (powder)	0.96
Earth	0.92 to 0.96	Lacquer	0.80 to 0.95
Water	0.92 to 0.96	Lacquer (matte)	0.97
Ice	0.96 to 0.98	Rubber (black)	0.94
Snow	0.83	Plastic	0.85 to 0.95
Glass	0.90 to 0.95	Timber	0.90
Ceramic	0.90 to 0.94	Paper	0.70 to 0.94
Marble	0.94	Chromium oxides	0.81
Plaster	0.80 to 0.90	Copper oxides	0.78
Mortar	0.89 to 0.91	Iron oxides	0.78 to 0.82
Brick	0.93 to 0.96	Textiles	0.90

Setup and Operation

1. Hold the meter by its handle grip and point it toward the surface to be measured.
2. Pull and hold the trigger to turn the meter on and begin testing. The display will light if the battery is good. Replace the battery if the display does not light.
3. While measuring, the **SCAN** icon will appear in the upper left-hand corner of the LCD.
4. Press the **°C/°F** button to select your desired temperature units.
5. Press the **Laser / Backlight** button to turn on the laser pointer. When the laser is on, the **Laser** icon will appear on the LCD. Quickly press the **Laser / Backlight** button again to turn laser off.
6. Press and hold the **Laser / Backlight** button to turn the backlight on or off.
7. Release the trigger and the **HOLD** icon will appear on the LCD indicating that the reading is being held.
8. Use the **MAX/MIN** button to display the maximum or minimum value.
9. To conserve battery life, the meter automatically powers down in 10 seconds once the trigger is released.

Specifications

Temperature range	-4 to 630°F (-20 to 332°C)
Resolution	0.1°F/C
Accuracy	±2.5 of reading or ±4.5°F (2.5°C)
Response time	Less than 1 second
Emissivity	Fixed at 0.95
Distance-to-sight ratio (field of view)	D/S = Approximately 10:1 ratio (D = distance, S = spot)
Laser	Single Class 2 (II) Laser
Spectral range	6 to 14 μm
Out-of-range indication	LCD will show "Hi/Lo"
Operating temperature	32 to 122°F (0 to 50°C)
Storage temperature	-14 to 140°F (-10 to 60°C)
Power	One 9 V battery

Field of View

The meter's field of view is 10:1, meaning that if the meter is 10 inches from the target, the diameter of the object under test must be at least 1 inch. Other distances are shown below in the field of view diagram below. Make sure that the target is larger than the unit's spot size.

The smaller the target, the closer you should be to it. When accuracy is critical, make sure the target is at least twice as large as the spot size.

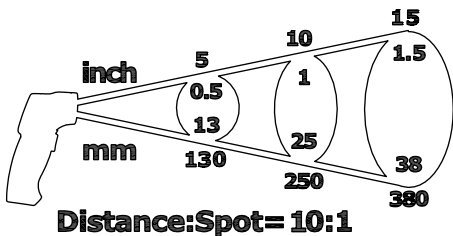

Safety

- Use extreme caution when the laser beam is turned on.
- Do not let the laser beam enter your eye, another person's eye or the eye of an animal.
- Be careful not to let the laser beam on a reflective surface strike your eye.
- Do not allow the laser light beam to impinge on any gas which can explode.



Maintenance, Recalibration, and Repair

Cleaning and Storage

- The meter should be cleaned with a damp cloth and mild detergent when necessary. Do not use solvents or abrasives.
- Store the meter in an area with moderate temperature and humidity (refer to the operating and storage temperatures on page 10).

Battery Replacement

If the battery power is insufficient, the **Low Battery** icon will appear on the LCD. Open the battery cover and replace the 9 V battery. Securely close the cover.

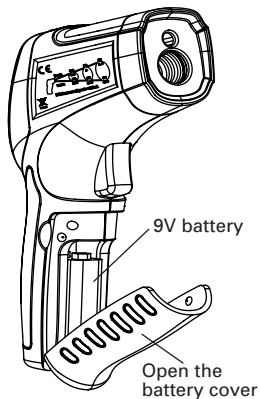

Maintenance, Recalibration, and Repair (Cont.)

It is recommended that Digi-Sense products are calibrated annually to ensure proper function and accurate measurements; however, your quality system or regulatory body may require more frequent calibrations.

For Product and Ordering Information, Contact:

Contact:
Industrial Process Measurement, Inc.
3910 Park Avenue, Unit 7
Edison, NJ 08820
732-632-6400
support@instrumentation2000.com
<http://www.instrumentation2000.com>