

PERFORMANCE

Maximum Hydraulic Pressure: **15 000 psi / 1000 bar / 100 MPa**

Vacuum: **-12.5 psi / -0.86 bar / -86.2 kPa**

Maximum Pneumatic Pressure: **400 inH₂O / 995 mbar / 29 inHg**

Sensitivity (fine adjust) **0.01 inH₂O / 0.025 mbar**

Burst Pressure: **> 25 000 psi / 1700 bar / 170MPa**

MATERIALS

Wetted Materials: **Stainless Steel plus Seals and Acrylic Reservoir**

Enclosure: **Anodized Aluminum**

Seals: **Buna N (Nitrile), Viton, and Urethane**

Test Media: **Water, Oil, or Air**

DIMENSIONS

Width: **8.3 in (210 mm)**

Length: **20.5 in (520 mm)**

Height (base): **5.5 in (140 mm)**

Height (with handles): **11 in (280 mm)**

Weight: **20 lbs (9 kg)**

Piston Stroke Volume: **0.8 in³ (13.1 cm³)**

Reservoir Volume: **10.8 in³ (176.9 cm³)**

CONNECTIONS

CPF Male (installed): **MAWP 15 000 psi / 1000 bar / 100MPa**

MPF15K-1/4FPT: **MAWP 15 000 psi / 1000 bar / 100MPa**

1/4" medium pressure tube system compatible with HiP LM4 and LF4 Series; and Autoclave Engr SF250CX Male and Female Series.

2 port pivoting manifold allows calibration of large gauges.

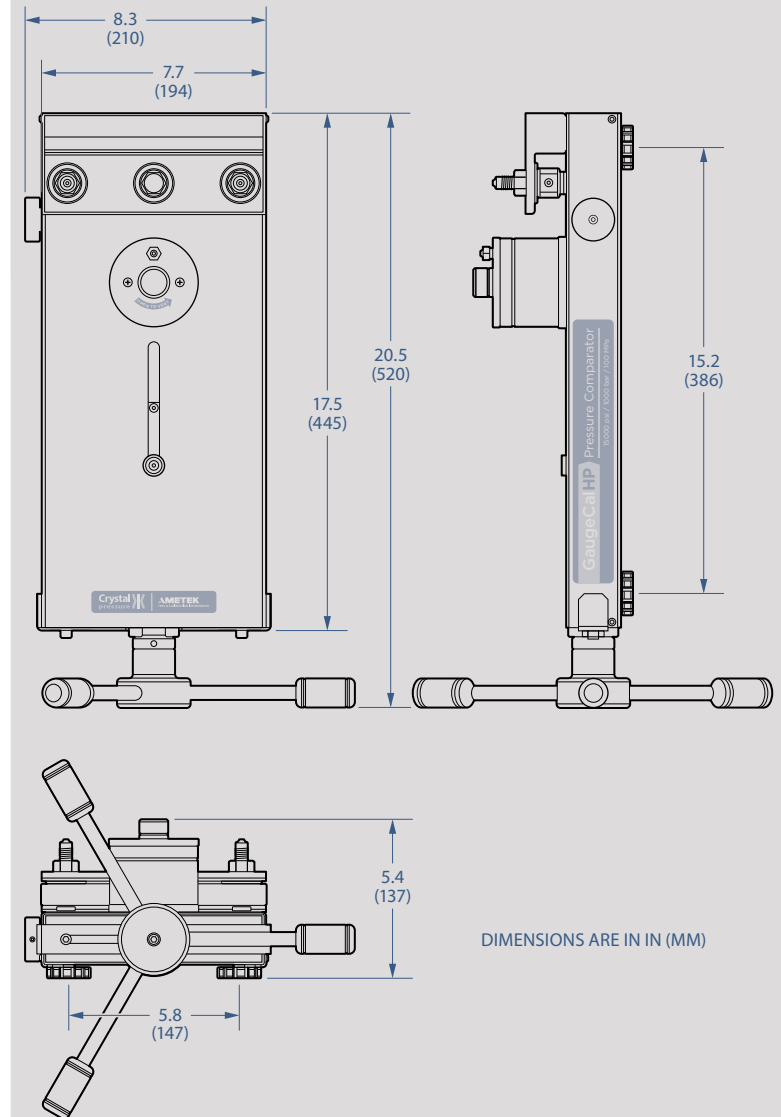

ORDERING

P/N GaugeCalHP: GaugeCalHP Pressure Comparator

Pressure Comparator, two CPF male fittings (installed), and one 1/4" FNPT adapter (P/N MPF15K-1/4FPT).

ACCESSORIES

P/N 5102: Fine Adjust (included)

P/N 5101: Rolling Case

Two MPF-CAP fittings to prevent leaks while in transit, two hold-down straps, and fluid bottle.

P/N FASTCALXP: Gauge and Transmitter Calibration Software

FastCalXP software, USB Security Key, CD, USB-RS232 adapter, and 30 series RS232 cable.

P/N 3327: USB Footswitch for FastCalXP

P/N 5103: Rebuild kit

COMPLEMENTARY PRODUCTS

Crystal Engineering offers a wide range of products that work with the GaugeCalHP:

- [Fittings that connect without tools, safely and without leaks](#)
- [Lightweight, super flexible high pressure hoses](#)
- [Fitting kits and adapters](#)
- [Digital Test Gauge](#)
- [Reference Recorder](#)
- [Pressure Calibrator](#)