

- FLEXIBLE
AC CURRENT SENSOR
High Frequency Response
for Oscilloscopes

MiniFlex[®]

MF 300-6-2-10-HF

MF 300-10-2-10-HF



Statement of Compliance

Chauvin Arnoux®, Inc. d.b.a. AEMC® Instruments certifies that this instrument has been calibrated using standards and instruments traceable to international standards.

We guarantee that at the time of shipping your instrument has met its published specifications.

An NIST traceable certificate may be requested at the time of purchase, or obtained by returning the instrument to our repair and calibration facility, for a nominal charge.

The recommended calibration interval for this instrument is 12 months and begins on the date of receipt by the customer. For recalibration, please use our calibration services. Refer to our repair and calibration section at **www.aemc.com**.

Serial #: _____

Catalog #: 2126.83 / 2126.84

Model #: MF 300-6-2-10 HF/ MF 300-10-2-10-HF

Please fill in the appropriate date as indicated:

Date Received: _____

Date Calibration Due: _____



Chauvin Arnoux®, Inc.
d.b.a AEMC® Instruments
www.aemc.com

Table of Contents

1. INTRODUCTION.....	2
1.1 International Electrical Symbols.....	3
1.2 Definition of Measurement Categories	3
1.3 Receiving Your Shipment.....	4
1.4 Ordering Information.....	4
1.4.1 Accessories and Replacement Parts	4
2. PRODUCT FEATURES	5
2.1 Description.....	5
2.2 Features.....	6
2.3 Control Features	7
3. SPECIFICATIONS.....	8
3.1 Typical Response Curves	10
3.1.1 Frequency Error.....	10
3.1.2 Amplitude Error.....	11
4. OPERATION	12
4.1 Compatibility	12
4.2 Tips for Making Precise Measurements.....	12
4.3 Making Measurements	13
5. MAINTENANCE	14
5.1 Maintenance	14
5.1.1 Battery Replacement	14
5.1.2 Cleaning.....	14
Repair and Calibration.....	15
Technical and Sales Assistance	15
Limited Warranty	16
Warranty Repairs.....	16







INTRODUCTION



These safety warnings are provided to ensure the safety of personnel and proper operation of the instrument.

- Read this instruction manual completely and follow all the safety information before attempting to use or service this instrument.
- Safety is the responsibility of the operator. The MiniFlex® must be used only by qualified personnel using applicable safety precautions.
- Wear protective clothing and gloves as required.
- Use caution on any circuit: potentially high voltages and currents may be present and may pose a shock hazard.
- Read the safety specifications section prior to using the current probe. Never exceed the maximum voltage ratings given.
- ALWAYS de-energize the circuit before wrapping the MiniFlex® around bare conductors, bus bars, or near live parts. Do not wrap on live conductors.
- ALWAYS connect the electronic module to the display device before wrapping the MiniFlex® around the sample being tested.
- ALWAYS inspect the module, sensor, sensor cable, and output terminals prior to use. Replace any defective parts immediately. Use only factory parts.
- NEVER use the MiniFlex® on electrical conductors rated above 1000V CAT III; 600V CAT IV.

1.1 International Electrical Symbols

	This symbol signifies that the instrument is protected by double or reinforced insulation.
	This symbol on the instrument indicates a WARNING and that the operator must refer to the user manual for instructions before operating the instrument. In this manual, the symbol preceding instructions indicates that if the instructions are not followed, bodily injury, installation/sample and product damage may result.
	Risk of electric shock. The voltage at the parts marked with this symbol may be dangerous.
	This symbol refers to a type B current sensor. Do not apply around or remove from HAZARDOUS LIVE conductors without additional protective means (de-energizing the circuit or wearing protective clothing suitable for high voltage work).
	Battery
	Compliance with the Low Voltage & Electromagnetic Compatibility European directives (73/23/CEE & 89/336/CEE)
	In the European Union, this product is subject to a separate collection system for recycling electrical and electronic components In accordance with directive WEEE 2002/96/EC

1.2 Definition of Measurement Categories

- CAT I:** For measurements on circuits not directly connected to the AC supply wall outlet such as protected secondaries, signal level, and limited energy circuits.
- CAT II:** For measurements performed on circuits directly connected to the electrical distribution system. Examples are measurements on household appliances or portable tools.
- CAT III:** For measurements performed in the building installation at the distribution level such as on hardwired equipment in fixed installation and circuit breakers.
- CAT IV:** For measurements performed at the primary electrical supply (<1000V) such as on primary overcurrent protection devices, ripple control units, or meters.

1.3 Receiving Your Shipment

Upon receiving your shipment, make sure that the contents are consistent with the packing list. Notify your distributor of any missing items. If the equipment appears to be damaged, file a claim immediately with the carrier and notify your distributor at once, giving a detailed description of any damage. Save the damaged packing container to substantiate your claim.

1.4 Ordering Information

MiniFlex® 30/300A, 6", 100mV/10mV/A High Frequency
(for use with any BNC Oscilloscope) **Cat. #2126.83**

MiniFlex® 30/300A, 10", 100mV/10mV/A High Frequency
(for use with any BNC Oscilloscope) **Cat. #2126.84**

Both models include a 9V battery and a user manual.

1.4.1 Accessories and Replacement Parts

Adapter - BNC (female) / 4mm Banana (male) **Cat. #2119.94**

Order Accessories and Replacement Parts Directly Online

Check our Storefront at www.aemc.com/store for availability

PRODUCT FEATURES

2.1 Description

The MiniFlex® HF is a compact flexible AC current transformer composed of a flexible sensor and an electronic module. It is designed to measure from 5Hz to 1MHz. The flexible sensor permits measurements on conductors where standard clamp-on probes could not be used. In particular, it can be installed in confined spaces, places where access is difficult, or even wrapped around irregular shapes.

The MiniFlex® HF is lightweight. It does not use magnetic cores like standard transformers. The transformation principle is based on an air core. It presents virtually no load to the system under test, has a low phase shift and excellent frequency response from 5Hz to 1MHz at -3db, and cannot be damaged by overloads. The sensor assembly is insulated for 1000V CAT III; 600V CAT IV. The MiniFlex® HF meets EN 61010 and is CE marked.

The MiniFlex® HF has an mV output proportional to the current measured for direct readings on oscilloscopes, DMMs, data loggers and power or harmonic meters. TRMS measurements are taken when connected to a TRMS meter. The MiniFlex® HF is insensitive to DC currents and only the AC component of the measured signal is measured.

The flexible sensor is available in lengths of 6" and 10".

2.2 Features

- Measures from 0.5Arms to 300Arms
- Accuracy 1% of Reading \pm 0.3A
- TRMS measurements when connected to a TRMS instrument
- No core saturation or damage if overloaded
- 9V battery for typical 140 hour continuous operation
- 1MHz frequency response
- Low phase shift for power measurements
- Insensitive to DC, measures only AC component on DC + AC signals
- Excellent linearity
- Lightweight
- Sensor is resistant to oils and aliphatic hydrocarbons
- EN 61010; 1000V CAT III; 600V CAT IV; CE Mark

2.3 Control Features

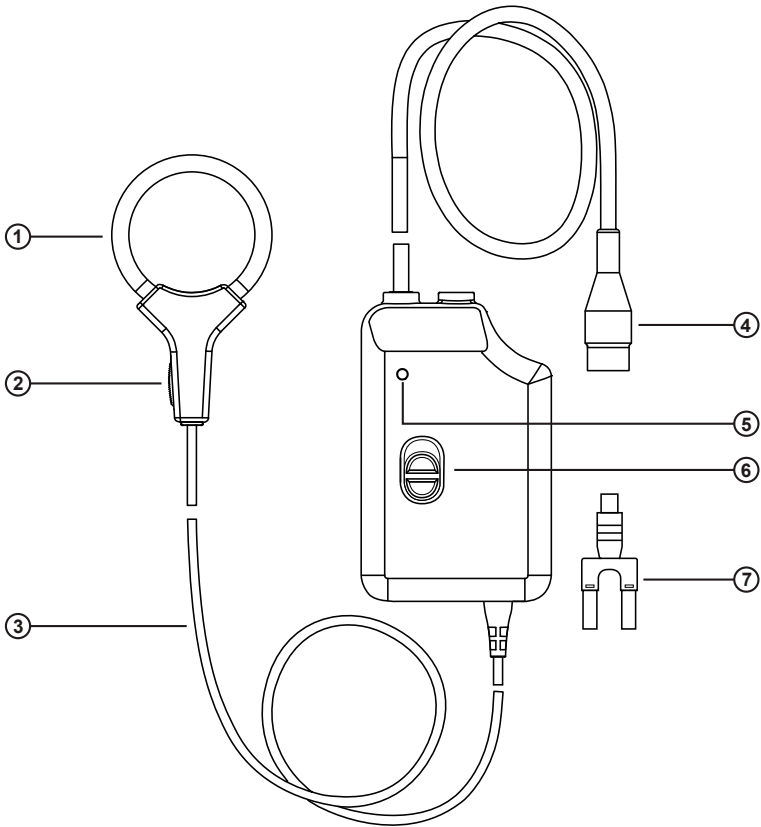

Figure 1

1. Flexible sensor 5mm Ø
2. Sensor opening device
3. Shielded cord
4. BNC output connector
5. Green ON/OFF indicator
6. Range selection switch:
 - Model MF 300-6-2-10-HF (30 / 300A)
 - Model MF 300-10-2-10-HF (300 / 300A)
7. Optional BNC (female) / Banana (male) connector

SPECIFICATIONS

REFERENCE CONDITIONS	
Quantity of influence	Reference values
Temperature	23 ± 5° C
Relative humidity	20 to 75% RH
Frequency of the signal measured	40 to 400Hz
Type of signal	Sinusoidal
External electric field	< 1V/m
External DC magnetic field (earth field)	< 40A/m
External AC magnetic field	None
Position of the conductor	Centered in the measurement coil
Shape of the measurement coil	Nearly circular
Input impedance of the display device connected to housing	≥1MΩ

MODEL	MF 300-6-2-10-HF	MF 300-10-2-10-HF
ELECTRICAL		
Range	30/300A	
Signal Output	100mV/10mV/A	
Frequency Range	5Hz to 1MHz @ -3dB	
Frequency Limitation	none	
Influence Of Conductor Positioning	1.5% typical, 3% max	
Influence Of Conductor Positioning In Sensor Against Handle	4% typical, 6% max	
External Conductor Influence	35dB to 40dB on contact	
Accuracy	± 1% +0.3A	
Common Mode Rejection	100dB typical, 80dB min	
Max peak factor⁽¹⁾ at I nominal	1.5	
Residual noise at I = 0 (Arms)⁽²⁾	0.3A	
Max phase shift at 1kHz (°)	1	
Max offset voltage (mVoc)	50	5
Max output voltage (Vpeak)	± 4.5	
Output impedance (kΩ)	1	
Power Source	9V alkaline battery (6LF22)	
Battery Life	140 hrs continuous operation or 10,000 one minute measurements	
Battery Indicator	When Green LED starts blinking, remaining life is approx 8 hours; When LED is OFF, the battery needs to be replaced	

(1): Peak factor PF = Vpeak/Vrms

(2): The residual noise affects the measurement uncertainty according to the formula:

$$\text{global uncertainty} = \frac{\sqrt{(I \text{ measured} \times 0.01)^2 + (\text{residual noise})^2}}{I \text{ measured}} \quad (I \text{ measured} \neq 0)$$

If the current measured is zero, the uncertainty is equal to the residual noise.

MODEL	MF 300-6-2-10-HF / MF 300-10-2-10-HF	
MECHANICAL		
Module Output	Coaxial cable terminated by an insulated female BNC connector	
Module Dimensions	4.0 x 2.5 x 1.1" (103 x 64 x 28mm)	
Module Weight	7 oz (200g)	
Sensor Diameter	5mm Ø	
Sensor Length	6" (152mm)	10" (250mm)
Max Conductor Size	1.77" (45mm)	2.95" (70mm)
Connection Cable Length	6.5 ft (2m)	
Flammability Rating	Sensor: UL94V0 Housing: UL94V2	
Drop Test	Per IEC 68-2-32	
Vibration	Per IEC 68-2-6	
Mechanical Shock	Per IEC 68-2-27	
Weatherproofing	IP 50	
ENVIRONMENTAL		
Operating Temperature Range	14° to 131°F (-10° to +55°C)	
Storage Temperature Range	-40° to 158°F (-40° to +70°C)	
Influence of Temperature	Sensor: -10° to 100°C: < 0.5% of Reading per 10°C Module: -10° to 55°C: < 0.5% of Reading per 10°C	
Relative Humidity	10 to 90% RH: 0.1% typical, 0.3% max	
Altitude	Operating: 0 to 2000m, working voltage derating above; Non-operating: 0 to 12,000m	
SAFETY		
Double Insulation	Yes, per IEC 1010-2-32	
CE Rated	Yes	
Safety Rating	EN 61010, 1000V CAT III; 600V CAT IV	
Pollution Level	2	
Immunity and Emission	Industrial environment	
Electromagnetic Compatibility	Satisfies the EMC and LVD directives required for CE marking and product standard IEC 61326-1 (Ed. 97) + A1 (Ed. 98)	

Specifications are subject to change without notice

3.1 Typical Response Curves

3.1.1 Frequency Error: Model MF 300-6-2-10-HF Diameter 45mm Model MF 300-10-2-10-HF Diameter 70mm

30A Range:

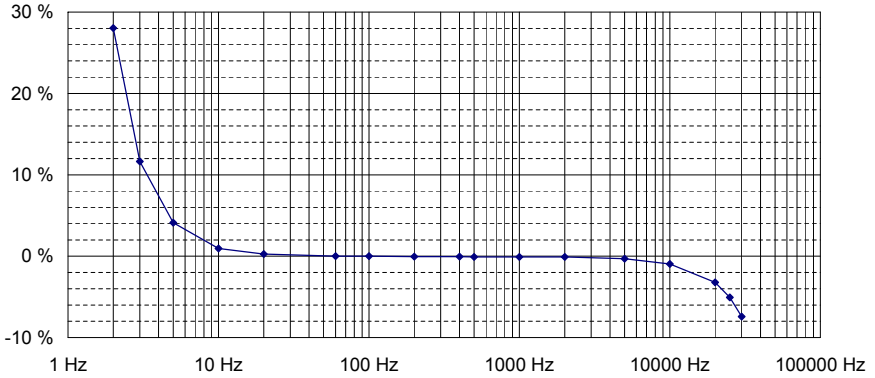

300A Range:

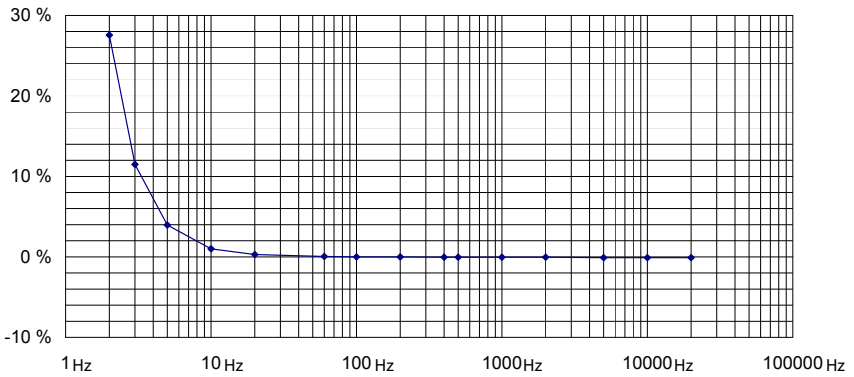

3.1.2 Amplitude Error - Diameter 45mm

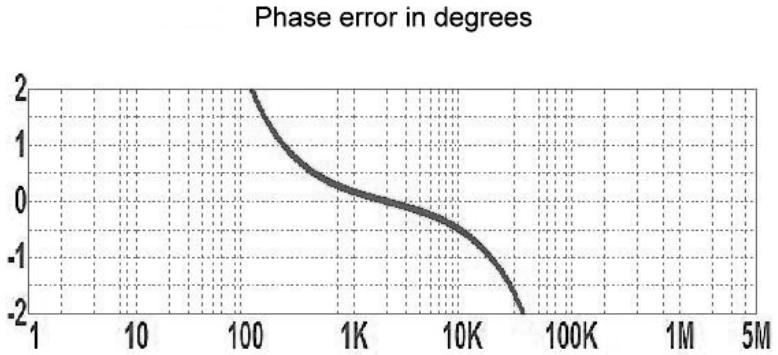
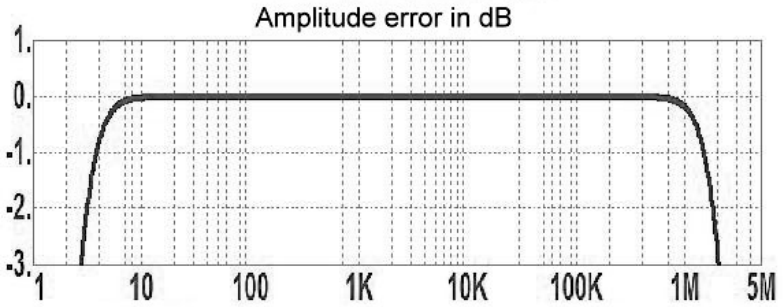

OPERATION

4.1 Compatibility

The MiniFlex[®] is compatible with any Oscilloscope, AC voltmeter, or other voltage measuring instrument with an input impedance greater than 1M Ω . To achieve the best overall accuracy, use the MiniFlex[®] with an Oscilloscope set to AC mode with an accuracy of 0.75% or better

4.2 Tips for Making Precise Measurements

- When using the MiniFlex[®] with an Oscilloscope, it is important to select the range that provides the best resolution. Failure to do this may result in measurement errors.
- For best results, select the highest MiniFlex[®] output signal possible and the most sensitive meter range for this output.
- Make sure the Oscilloscope or measuring instrument can accurately measure mVAC.
- For best accuracy, center the MiniFlex[®] around the conductor to be measured.
- The overall measurement accuracy is the sum of the MiniFlex[®] accuracy and the displaying instrument accuracy.

4.3 Making Measurements

- Connect the electronic module to the AC Volt range of a Oscilloscope input or measuring instrument. Select the highest range on the Mini-Flex®.

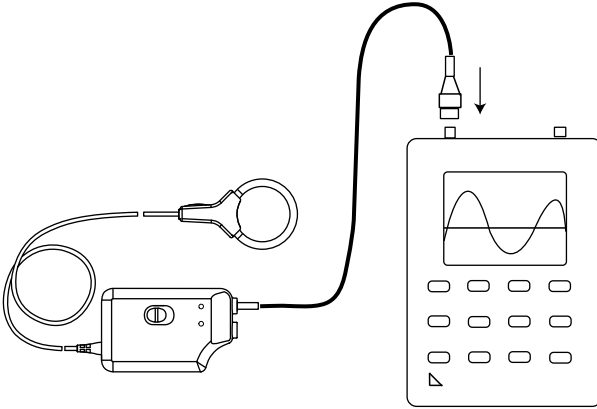

- Press the sensor's yellow opening device to open the flexible coil.
- Wrap the coil around the conductor to be tested. If possible, within range, select the lowest range to obtain the best resolution.

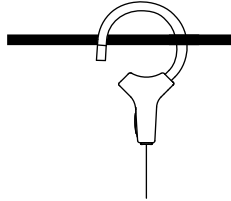

- Do not exceed specified current range for the output.
- Read the displayed value on the Oscilloscope and divide it by the range selected (i.e. if reading = 2.59V with the 10mV/A output range, the current flowing through the probe is $2590\text{mV} \div 10 = 259\text{A}$).
- For best accuracy, carefully center the conductor inside the flexible core, and if possible, avoid being in the proximity of other conductors which may create noise and interference (particularly near the latch).

MAINTENANCE

5.1 Maintenance



Warning

- For maintenance use only specified replacement parts.
- To avoid electrical shock, do not attempt to perform any servicing unless you are qualified to do so.
- To avoid electrical shock and/or damage to the instrument, do not get water or other foreign agents into the case.
- Turn the instrument OFF and disconnect the unit from all the circuits before opening the case.

5.1.1 Battery Replacement

The battery must be replaced when the green indicator flashes or remains off when the instrument is switched on.

- Disconnect everything connected to the instrument and set the switch to OFF.
- Use a screwdriver to unscrew the two screws on the housing.
- Replace the old battery with a new one (9V alkaline or lithium battery of type 6LF22).
- Close the housing, making sure that it is completely and correctly closed, then screw both screws back in.

5.1.2 Cleaning

- It is important to keep the sensor latch mating surfaces clean to prevent foreign matter from entering the closing.
- The sensor may be gently cleaned with a soft cloth, soap and water. Dry immediately after cleaning. Avoid water penetration into the electronic module.
- Make sure the sensor, electronic module, and all leads are completely dry before any further use.

Repair and Calibration

To ensure that your instrument meets factory specifications, we recommend that it be scheduled back to our factory Service Center at one-year intervals for recalibration, or as required by other standards or internal procedures.

For instrument repair and calibration:

You must contact our Service Center for a Customer Service Authorization Number (CSA#). This will ensure that when your instrument arrives, it will be tracked and processed promptly. Please write the CSA# on the outside of the shipping container. If the instrument is returned for calibration, we need to know if you want a standard calibration, or a calibration traceable to N.I.S.T. (Includes calibration certificate plus recorded calibration data).

Ship To: Chauvin Arnoux®, Inc. d.b.a. AEMC® Instruments
15 Faraday Drive
Dover, NH 03820 USA
Phone: (800) 945-2362 (Ext. 360)
(603) 749-6434 (Ext. 360)
Fax: (603) 742-2346 or (603) 749-6309
E-mail: repair@aemc.com

(Or contact your authorized distributor)

Costs for repair, standard calibration, and calibration traceable to N.I.S.T. are available.

NOTE: You must obtain a CSA# before returning any instrument.

Technical and Sales Assistance

If you are experiencing any technical problems, or require any assistance with the proper operation or application of your instrument, please call, mail, fax or e-mail our technical support team:

Chauvin Arnoux®, Inc. d.b.a. AEMC® Instruments
200 Foxborough Boulevard
Foxborough, MA 02035 USA
Phone: (800) 343-1391
(508) 698-2115
Fax: (508) 698-2118
E-mail: techsupport@aemc.com
www.aemc.com

NOTE: Do not ship Instruments to our Foxborough, MA address.

Limited Warranty

The MiniFlex® is warranted to the owner for a period of one year from the date of original purchase against defects in manufacture. This limited warranty is given by AEMC® Instruments, not by the distributor from whom it was purchased. This warranty is void if the unit has been tampered with, abused or if the defect is related to service not performed by AEMC® Instruments.

Full warranty coverage and product registration is available on our website at www.aemc.com/warranty.html.

Please print the online Warranty Coverage Information for your records.

What AEMC® Instruments will do:

If a malfunction occurs within the one-year period, you may return the instrument to us for repair, provided we have your warranty registration information on file or a proof of purchase. AEMC® Instruments will, at its option, repair or replace the faulty material.

**REGISTER ONLINE AT:
www.aemc.com**

Warranty Repairs

What you must do to return an Instrument for Warranty Repair:

First, request a Customer Service Authorization Number (CSA#) by phone or by fax from our Service Department (see address below), then return the instrument along with the signed CSA Form. Please write the CSA# on the outside of the shipping container. Return the instrument, postage or shipment pre-paid to:

Ship To: Chauvin Arnoux®, Inc. d.b.a. AEMC® Instruments
15 Faraday Drive • Dover, NH 03820 USA
Phone: (800) 945-2362 (Ext. 360)
(603) 749-6434 (Ext. 360)
Fax: (603) 742-2346 or (603) 749-6309
E-mail: repair@aemc.com

Caution: To protect yourself against in-transit loss, we recommend you insure your returned material.

NOTE: You must obtain a CSA# before returning any instrument.



08/13

99-MAN 100349 v6