

- AC/DC LOW CURRENT CLAMP-ON METER

CM605



Statement of Compliance

Chauvin Arnoux®, Inc. d.b.a. AEMC® Instruments certifies that this instrument has been calibrated using standards and instruments traceable to international standards.

We guarantee that at the time of shipping your instrument has met its published specifications.

An NIST traceable certificate may be requested at the time of purchase, or obtained by returning the instrument to our repair and calibration facility, for a nominal charge.

The recommended calibration interval for this instrument is 12 months and begins on the date of receipt by the customer. For recalibration, please use our calibration services. Refer to our repair and calibration section at www.aemc.com.

Serial #: _____

Catalog #: 7000.02

Model #: CM605

Please fill in the appropriate date as indicated:

Date Received: _____

Date Calibration Due: _____



AEMC®
INSTRUMENTS

Chauvin Arnoux®, Inc.
d.b.a AEMC® Instruments
www.aemc.com

Table of Contents

1. INTRODUCTION.....	2
1.1 International Electrical Symbols.....	3
1.2 Receiving Your Shipment.....	3
1.3 Ordering Information.....	3
2. PRODUCT FEATURES	4
2.1 Control Features.....	4
2.2 Display Features.....	5
2.3 Button Functions.....	5
2.3.1 HOLD/PEAK Button.....	5
2.3.2 ZERO Button.....	5
3. SPECIFICATIONS.....	6
3.1 Electrical Specifications.....	6
3.2 Environmental Specifications.....	7
3.3 Mechanical Specifications.....	8
3.4 Safety Specifications.....	8
4. OPERATION	9
4.1 Preparation Before Use.....	9
4.2 AC Current Measurement.....	10
4.3 DC Current Measurement.....	11
4.4 AC Voltage Measurement.....	12
4.5 DC Voltage Measurement.....	13
4.6 Resistance Measurement.....	14
4.7 Continuity Test.....	15
4.8 Analog Output.....	16
5. MAINTENANCE	17
5.1 Warning.....	17
5.2 Battery Replacement.....	17
5.3 Cleaning.....	17
Repair and Calibration.....	18
Technical and Sales Assistance.....	18
Limited Warranty.....	19
Warranty Repairs.....	19

INTRODUCTION



These safety warnings are provided to ensure the safety of personnel and proper operation of the instrument.

- Read the instruction manual completely and follow all safety information before operating this instrument.
- Only use leads that comply with the IEC/EN 61010. Before using them, make sure that they are in safe working order.
- Only use factory supplied leads.
- Never exceed the protection limit values indicated in the specifications for each type of measurement.
- Never measure current while the test leads are connected to the input jacks.
- Use extreme caution when measuring live systems with voltages greater than 50VDC or 30VAC.
- Do not perform resistance or continuity tests on a live circuit.
- Use extreme care when working around bus bars and bare conductors.
- Do not use the meter in overrange/overload conditions (OL).
- When the multimeter clamp is linked to the measurement circuits, do not touch any unused terminals.
- Before changing the function, disconnect the measurement leads from the circuit measured.

1.1 International Electrical Symbols



This symbol signifies that the instrument is protected by double or reinforced insulation. Use only specified replacement parts when servicing the instrument.



This symbol on the instrument indicates a WARNING and that the operator must refer to the user manual for instructions before operating the instrument. In this manual, the symbol preceding instructions indicates that if the instructions are not followed, bodily injury, installation/sample and product damage may result.



Risk of electric shock. The voltage at the parts marked with this symbol may be dangerous.

1.2 Receiving Your Shipment

Upon receiving your shipment, make sure that the contents are consistent with the packing list. Notify your distributor of any missing items. If the equipment appears to be damaged, file a claim immediately with the carrier and notify your distributor at once, giving a detailed description of any damage. Save the damaged packing container to substantiate your claim. Do not use an instrument that appears to be damaged.

1.3 Ordering Information

Model CM605 **Cat. #7000.02**
Includes clamp-on meter, lead set (red & black lead) with needle point test probes, carrying case, 2x1.5V AAA batteries and a user manual.

PRODUCT FEATURES

2.1 Control Features

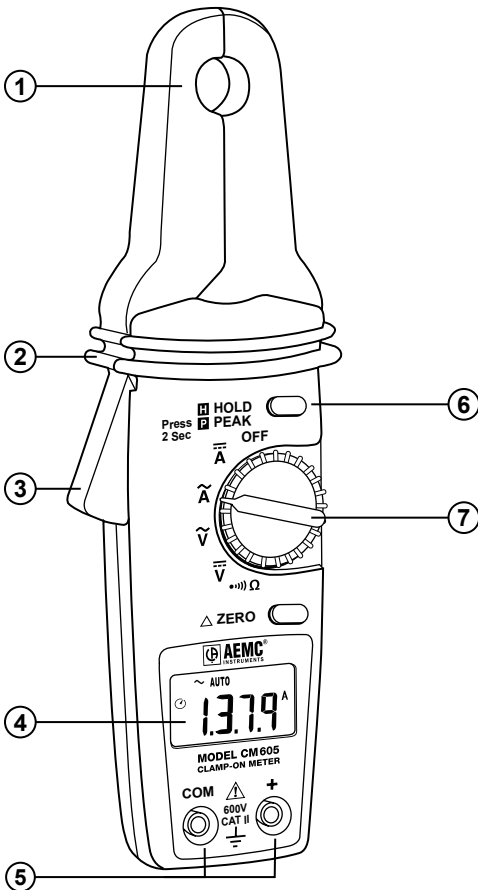

1. Tapered jaws for crowded wiring or areas (Ø.45" - 12mm)
2. Safety barrier anti-slip guard
3. Lever for jaw opening/closing
4. LCD display
5. COM (Black) and Positive (Red) input terminal jacks
6. Data hold and Peak hold buttons
7. Rotary range selector switch

2.2 Display Features

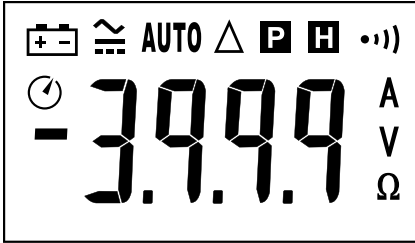

	Negative polarity
	Auto shutdown
	Low battery
	AC mode
	DC mode
AUTO	Auto range
	Zero (Relative)
P	Peak function
H	Hold function
	Continuity
A V	Current / Voltage
Ω	Resistance

2.3 Button Functions

2.3.1 HOLD/PEAK Button

Data Hold Function: This function locks the displayed value.

- To activate, press this button during the measurement. The **H** symbol appears and the measurement is locked.
- To deactivate, press the button again.

Peak Hold Function: This function displays the peak value.

- To activate, press this button during a measurement until the **P** symbol appears.
- The highest measurement is stored in memory.
- To deactivate the PEAK function, press and hold down the button for approximately 2 seconds.

2.3.2 ZERO Button

- To activate, press the **ZERO** button to enter the Zero mode.
- The symbol will appear and Zero the display. The reading is stored as a reference value for subsequent measurements.
- To exit the Zero mode, press the **ZERO** button again.

SPECIFICATIONS

3.1 Electrical Specifications

Reference Conditions: Accuracy given @ 23°C ± 5°C, 80% RH Max, Conductor centered in jaws, 45-65Hz, No DC Component.

AC Current (\tilde{A})

Range	Resolution	Accuracy	Frequency
10A	1mA	2.0% R ± 10cts	50 to 500Hz
100A	10mA	80A: 2.0% R ± 10cts >80A: 3.5% R ± 10cts	

DC Current (\bar{A}) - Positive only*

Range	Resolution	Accuracy
10A	1mA	2.5% R ± 10cts
100A	10mA	80A: 2.5% R ± 10cts >80A: 4.5% R ± 10cts

AC Volts (\tilde{V})

Range	Resolution	Accuracy	Impedance	Frequency
600V	100mV	1.5% R ± 5cts	10M Ω , <50pF	40 to 500Hz

Overload Protection: 660Vrms

DC Volts (\bar{V}) - Positive only*

Range	Resolution	Accuracy	Input Impedance
600V	100mV	1.0% R ± 2cts	10M Ω

Overload Protection: 660Vrms

** For negative measurement, add 2cts to the accuracy*

Resistance (Ω)

Range	Resolution	Accuracy	Test Voltage	Protection
10k Ω (9999 Ω)	1 Ω	1.0% R \pm 3cts	<3.0VDC	600Vrms

Continuity (••))

Buzzer	Resolution	Test Voltage	Protection
<100 Ω \pm 25 Ω	1 Ω	<3.0VDC	600Vrms

Analog Output

Range	Output	Frequency	Output Impedance
AAC & ADC	10mV/A through front banana jacks	0 to 20kHz @ \pm 3db	3k Ω , <50pF

Digital display: 10,000-count 4 digit LCD display (9999 max)

Polarity:

When a negative signal is applied, the  symbol appears.

Overload:

If the range is exceeded, the \overline{OL} symbol is displayed.

Low Battery Indicator:

 is displayed when the voltage supplied by the batteries is lower than the operating voltage.

Power Supply:

2 batteries - 1.5V type AAA (LR03)

Auto-off:

Automatic shut down after approx 10 minute with over-ride

Sampling:

Approx 2 measurements/second

3.2 Environmental Specifications

Operating Temperature:

32° to 104°F (0° to 40°C), < 80% RH max non-condensing

Storage Temperature:

14° to 140°F (-10° to 60°C), < 70% RH max non-condensing

Altitude: 6000 ft (2000m)

3.3 Mechanical Specifications

Maximum Cable Diameter:

Ø 0.45" (12mm)

Maximum Jaw Opening:

Ø 0.60" (15mm)

Dimensions:

7.44 x 2.80 x 1.46" (189 x 71 x 37mm)

Weight:

6.5 oz (180g)

3.4 Safety Specifications

IEC/EN 61010-1, 600V CAT II, 300V CAT III

- Insulation: Class II
- Pollution Degree: 2



OPERATION

4.1 Preparation Before Use



For your own safety and to prevent damage to the instrument, follow the instructions given in this manual.

This instrument can be used for measurements:

- on circuits in installation Category II, in an environment with pollution level 2, for voltages no greater than 600V in relation to the earth.
- or on circuits in installation Category III, in an environment with pollution degree level 2, for voltages no greater than 300V in relation to the earth.

Definition of the installation categories (see IEC/EN 61010-1 publication):

CAT II: CAT II circuits are household or similar appliance power circuits, which may carry medium-level transient over-voltage.

Example: household appliance and portable tool power supplies

CAT III: CAT III circuits are high-power appliance power circuits, which may carry high-level transient over-voltage.

Example: industrial machinery or instrument power supplies

For your own safety, only use factory supplied leads and always check that they are in perfect working order.

4.2 AC Current Measurement

- Turn the switch to the \tilde{A} range.
- Remove the test leads before measuring current .
- Clamp the jaws around the conductor to be measured.
- Take the current reading after it stabilizes.



WARNING: Immediately remove the test probes from the circuit under test if overload “OL” is displayed.

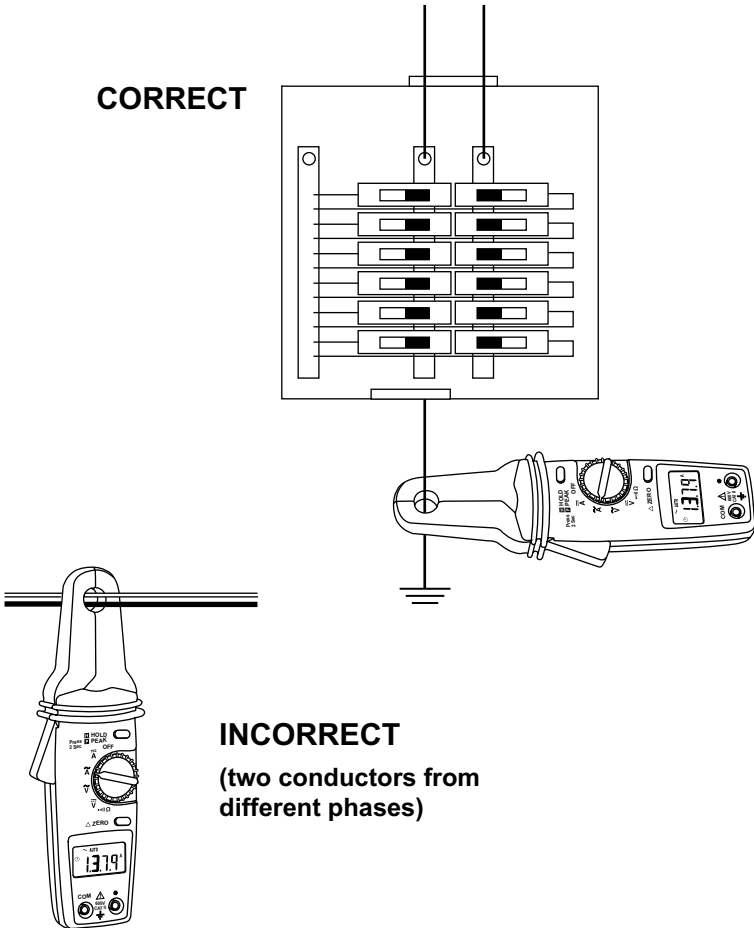

4.3 DC Current Measurement

NOTE: Remove the test leads before measuring current

- Turn the rotary range switch to the $\overline{\text{A}}$ range.
- If needed, the display may be “zeroed”. Press the ZERO button to zero the reading.
- Press the lever to open the jaws.
- Clamp the jaws around the conductor to be measured.
- If reading is unstable and is hard to read, push the **HOLD** button and read the measurement.



WARNING: Immediately unclamp the meter from the conductor under test if overload "OL" is displayed.

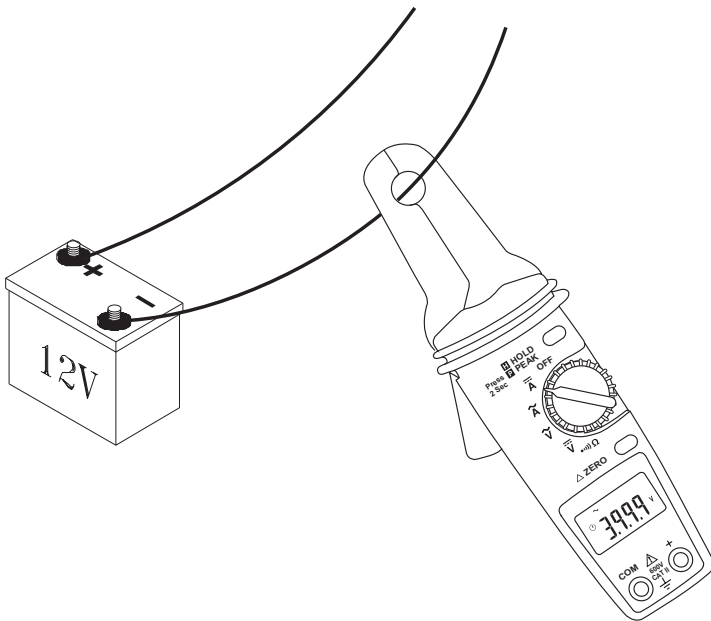

4.4 AC Voltage Measurement

Automatic measurement range: 600VAC/DC

- Turn the switch to the \tilde{V} range.
- Insert the red lead to the red "+" input jack and the black lead to the black "COM" input jack.
- Bring the test probe tips into contact with the test points.
- Take the voltage reading after it stabilizes.



WARNING: Immediately remove the test probes from the circuit under test if overload "OL" is displayed.

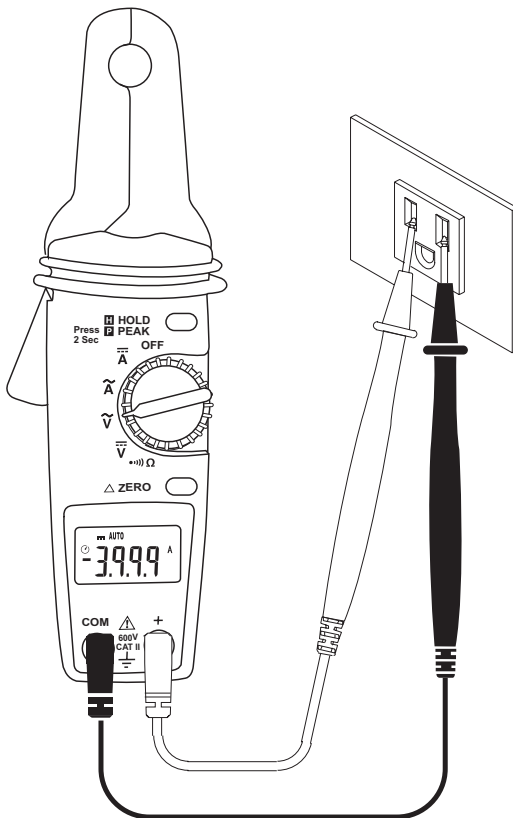

4.5 DC Voltage Measurement

Automatic measurement range: 600VAC/DC

- Turn the switch to the \bar{V} range.
- Insert the red lead to the red "+" input jack and the black lead to the black "COM" input jack.
- Take the voltage reading after it stabilizes.



WARNING: Immediately remove the test probes from the circuit under test if overload "OL" is displayed.

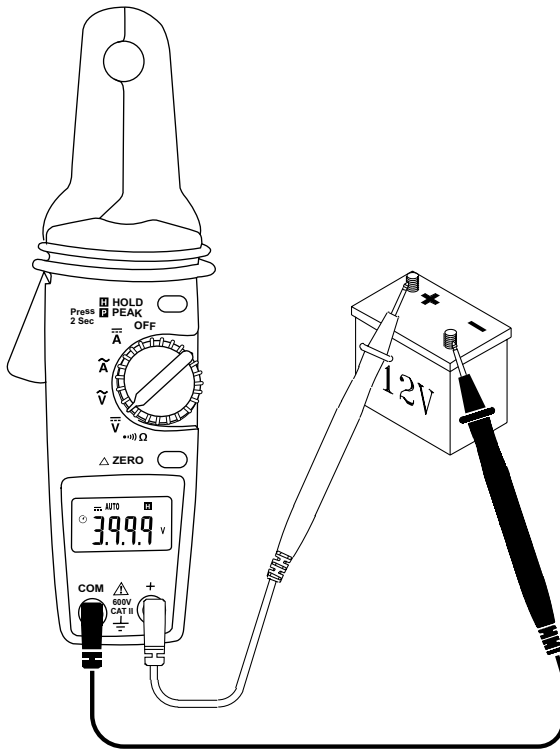

4.6 Resistance Measurement

Automatic measurement ranges: 0 to 10k Ω



WARNING: When making a resistance measurement, make sure that the power is off (dead circuit). It is also important that all capacitors in the measured circuit be fully discharged.

- Turn the rotary switch to the Ω range.
- Insert the red lead to the red “+” input jack and the black lead to the black “COM” input jack.
- Bring the test probe tips into contact with the sample under test.



WARNING: If overload “OL” is displayed, the resistance exceeds the measurement range or the circuit is open.

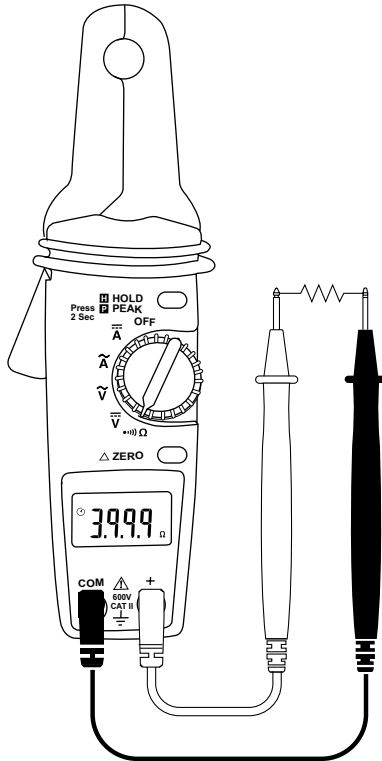

4.7 Continuity Test



WARNING: When testing continuity, make sure that the power is off (dead circuit).

- Turn the rotary switch to the Ω range..
- Insert the red lead to the red "+" input jack and the black lead to the black "COM" input jack.
- Bring the test probe tips into contact with the sample under test.
- The buzzer sounds when the circuit to be checked is DC or has a resistance of less than $100\Omega \pm 25\Omega$.



WARNING: If overload "OL" is displayed, the continuity exceeds the measurement range or the circuit is open.

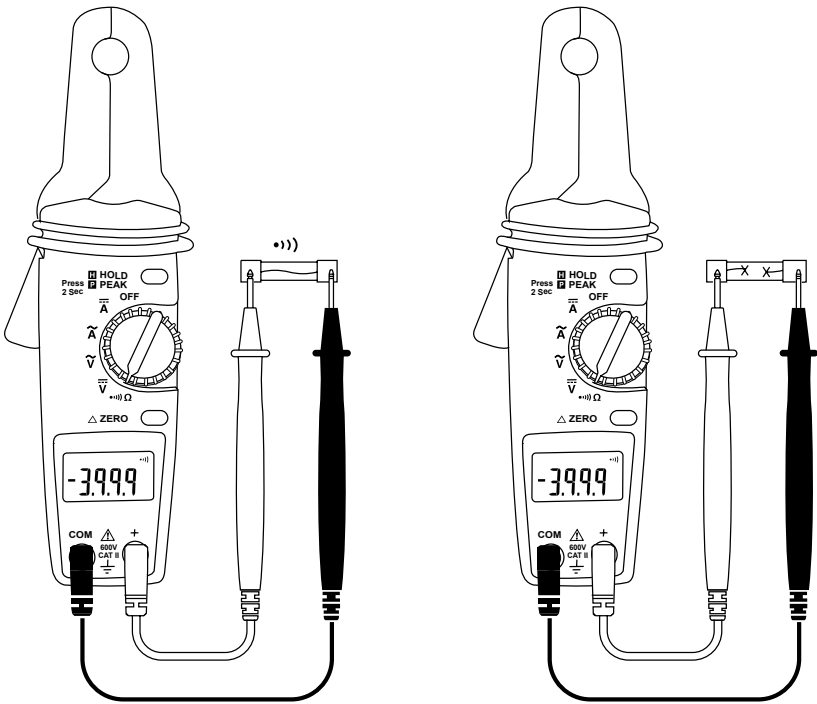

4.8 Analog Output

- Turn the rotary switch to the \tilde{A} or \overline{A} range.
- Insert the red lead to the red "+" input jack and the black lead to the black "COM" input jack.
- Connect the ends of both cables to an oscilloscope or another multimeter.
- Clamp the jaws around the conductor to be measured.
- Read the analog signal on the oscilloscope or multimeter.
 - If the signal measured is continuous, the output signal will be DC.
 - If the signal measured is alternating, the output signal will be AC.

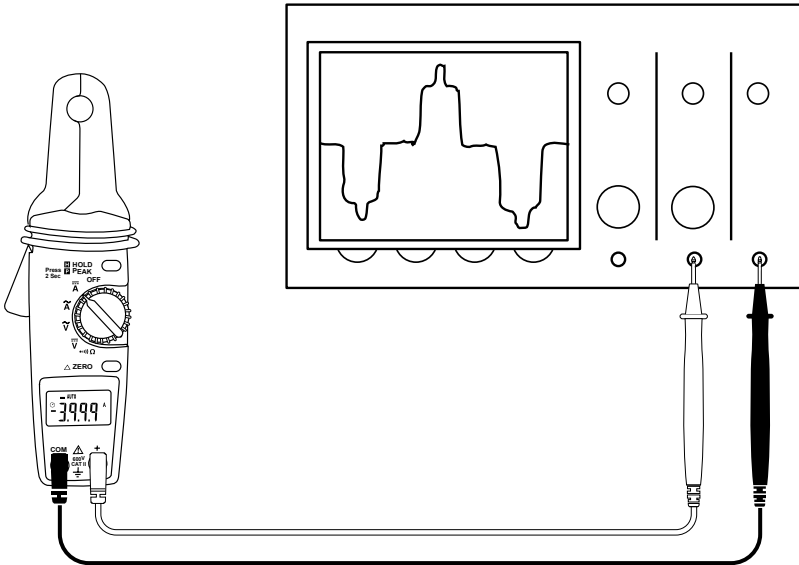

MAINTENANCE

5.1 Warning

- Remove the test leads from any input before opening the case. Do not operate the instrument without a battery case cover.
- To avoid electrical shock, do not attempt to perform any servicing unless you are qualified to do so.
- If the meter is not going to be used for a long period of time, take out the batteries. Do not store the meter in high temperatures or high humidity.
- To avoid electrical shock and/or damage to the instrument, do not get water or other foreign agents into the probe.

5.2 Battery Replacement

- The batteries will need to be replaced when the  symbol appears on the display.
- The meter must be in the OFF position and disconnected from any circuit or input.
- Remove the battery cover screws with a screwdriver.
- Replace the old batteries with two new 1.5V AAA (LR03) batteries.
- Replace the battery compartment cover and tighten the screws.

5.3 Cleaning

- To clean the instrument, wipe the case with a damp cloth and mild detergent. Do not use abrasives or solvents.
- Do not get water inside the case. This may lead to electrical shock or damage to the instrument.

Repair and Calibration

To ensure that your instrument meets factory specifications, we recommend that it be scheduled back to our factory Service Center at one-year intervals for recalibration, or as required by other standards or internal procedures.

For instrument repair and calibration:

You must contact our Service Center for a Customer Service Authorization Number (CSA#). This will ensure that when your instrument arrives, it will be tracked and processed promptly. Please write the CSA# on the outside of the shipping container. If the instrument is returned for calibration, we need to know if you want a standard calibration, or a calibration traceable to N.I.S.T. (Includes calibration certificate plus recorded calibration data).

Ship To: AEMC® Instruments
15 Faraday Drive
Dover, NH 03820 USA
Tel: (800) 945-2362 (Ext. 360)
(603) 749-6434 (Ext. 360)
Fax: (603) 742-2346 or (603) 749-6309
repair@aemc.com

(Or contact your authorized distributor)

Costs for repair, standard calibration, and calibration traceable to N.I.S.T. are available.

NOTE: You must obtain a CSA# before returning any instrument.

Technical and Sales Assistance

If you are experiencing any technical problems, or require any assistance with the proper operation or application of your instrument, please call, mail, fax or e-mail our technical support team:

AEMC® Instruments
200 Foxborough Boulevard
Foxborough, MA 02035 USA
Phone: (800) 343-1391
(508) 698-2115
Fax: (508) 698-2118
techsupport@aemc.com
www.aemc.com

NOTE: Do not ship Instruments to our Foxborough, MA address.

Limited Warranty

The Model CM 605 is warranted to the owner for a period of one year from the date of original purchase against defects in manufacture. This limited warranty is given by AEMC®, not by the distributor from whom it was purchased. This warranty is void if the unit has been tampered with, abused or if the defect is related to service not performed by AEMC®.

For full and detailed warranty coverage, go to www.aemc.com. The warranty information is located in our customer service section.

What AEMC® will do:

If a malfunction occurs within the one-year period, you may return the instrument to us for repair, provided you submit a proof of purchase. AEMC® will, at its option, repair or replace the faulty material.

Warranty Repairs

What you must do to return an Instrument for Warranty Repair:

First, request a Customer Service Authorization Number (CSA#) by phone or by fax from our Service Department (see address below), then return the instrument along with the signed CSA Form. Please write the CSA# on the outside of the shipping container. Return the instrument, postage or shipment pre-paid to:

AEMC® Instruments
Service Department
15 Faraday Drive • Dover, NH 03820 USA
Tel: (800) 945-2362 (Ext. 360)
(603) 749-6434 (Ext. 360)
Fax: (603) 742-2346 or (603) 749-6309

Caution: To protect yourself against in-transit loss, we recommend you insure your returned material.

NOTE: You must obtain a CSA# before returning any instrument.

Notes:



11/09

99-MAN 100346 v1

Chauvin Arnoux®, Inc. d.b.a. **AEMC®** Instruments
15 Faraday Drive • Dover, NH 03820 USA • Phone: (603) 749-6434 • Fax: (603) 742-2346
www.aemc.com